



Information Networking at Kärcher

Synchronizing Data from SAP, CATIA and PARTsolutions

Agenda

- Introduction of Speaker
- Introduction of Kärcher
- Idea and Qualifications
- Implementation of Part Management
- Implementation of Classification
- Future Prospects

Your Speaker

- Edgar Ossinger
- Engineering technician
- Working at Kärcher since 1988
- Responsible for assembly and maintenance of
 - classifications
 - Variant configurations in SAP
- Involved in introduction of
 - SAP PDM
 - SAP PLM
 - SAP variant configuration
 - CATIA V4
 - CATIA V5
 - PARTsolutions
- Administration
 - Translation of material naming into 8 languages
 - PARTsolutions and their interfaces
- Training coworkers in the classification environments



History



Company was founded by Alfred Kärcher

Auszug der wichtigsten Neuheiten im KÄRCHER-Programm.



Strategy of concentration on cleaning



Product range of 2.200 products

1935 1950

Development of first European hot-water high-pressure cleaner



1974

Strategy of concentration on the core business high-pressure cleaning. Color changed from blue to yellow.



1980

1984

Kärcher enters consumer business with first portable pressure washer, the HD 555 profi.



2001 actual

Strategic focus on brand, target groups, distribution channels and innovations



Core competency



Cleaning and supply of liquids



Cleaning of buildings and surfaces

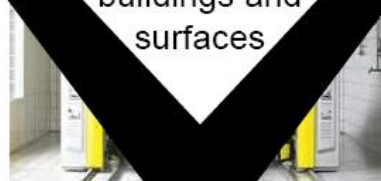

Cleaning of vehicles



Degree of innovation

Age of units
(in % of units sold in 2009)

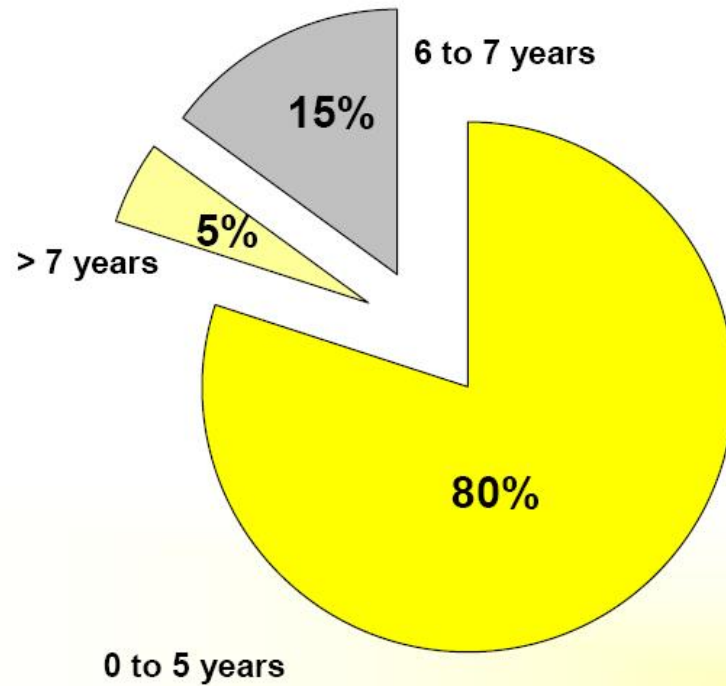

Business Units



Home & Garden

Pressure Washers



Home Cleaning



Garden



Professional

Commercial



Professional



Industrial



Kärcher Future-tech



Water Treatment



Logistics & production locations (18)



- Material search with graphic support
- Recognize whether there is a 3-D model for found parts
- Simple insertion and positioning of found 3-D models in CATIA V5
- Access to classifications without SAP also externally

- SAP as central data/information bearer
- Automatic data exchange between uses

Initial Situation



cent
CDI interface

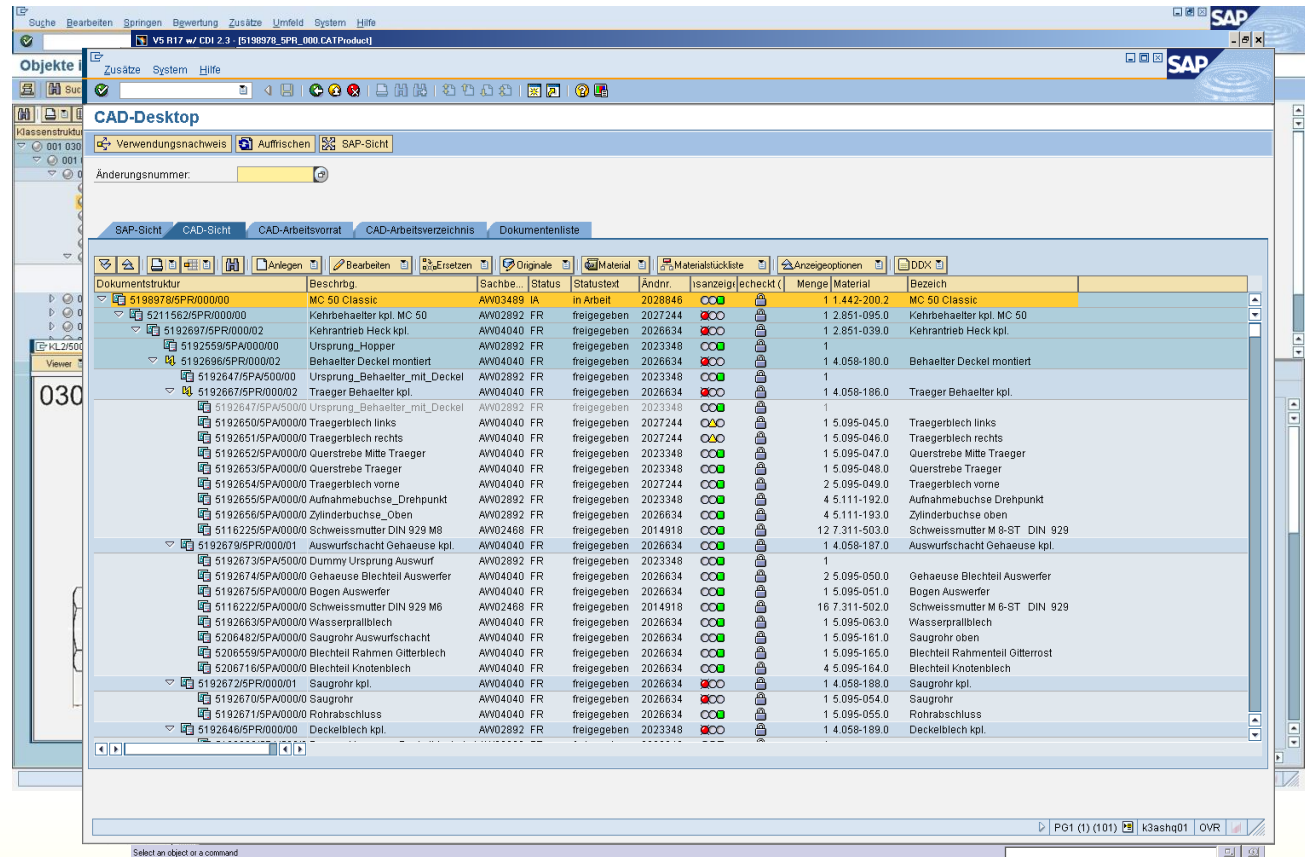

The screenshot shows the SAP CAD-Desktop interface with a BOM table. The table columns include: Dokumentstruktur, Beschrg, Sachbe..., Status, Statustext, Ändnr., |s|anzeigen|, |e|check|, Menge, Material, and Bezeich. The table lists various components of the MC 50 Classic, including MC 50 Classic, Kehrbehälter kpl., Ursprung_Hüpper, Behälter Deckel montiert, Traeger Behälter kpl., Traeger Behälter mit Deckel, Traegerblech links/rechts, Querstrebe Mitte/Traeger, Querstrebe vorne, Aufnahmebuchse Drehpunkt, Zylinderbuchse oben, Schweissmutter DIN 929 M8, Auswurfschacht Gehäuse kpl., Dummy Ursprung Auswurf, Gehäuse Blechteil Auswerfer, Bogen Auswerfer, Wasserprallblech, Saugrohr Auswurfschacht, Blechteil Rahmen Gitterrost, Blechteil Knotenblech, Saugrohr kpl., Saugrohr, Rohrabchluss, and Deckelblech kpl.

Dokumentstruktur	Beschrg	Sachbe...	Status	Statustext	Ändnr.	s anzeigen	e check	Menge	Material	Bezeich
5198978/SPR/000000	MC 50 Classic	AW03489 IA	In Arbeit	2028846				1	1.442-200.2	MC 50 Classic
5211562/SPR/000000	Kehrbehälter kpl. MC 50	AW02892 FR	freigegeben	2027244				1	2.851-095.0	Kehrbehälter kpl. MC 50
5192837/SPR/000002	Kehrantrieb Heck kpl.	AW04040 FR	freigegeben	2026634				1	2.851-039.0	Kehrantrieb Heck kpl.
5192538/SPR/000000	Ursprung_Hüpper	AW02892 FR	freigegeben	2023348				1		
5192636/SPR/000002	Behälter Deckel montiert	AW04040 FR	freigegeben	2026634				1	1.4.058-180.0	Behälter Deckel montiert
5192647/SPA/500000	Ursprung_Behälter_mit_Deckel	AW02892 FR	freigegeben	2023348				1		
5192687/SPR/000002	Traeger Behälter kpl.	AW04040 FR	freigegeben	2026634				1	1.4.058-186.0	Traeger Behälter kpl.
5192647/SPA/500000	Ursprung_Behälter_mit_Deckel	AW02892 FR	freigegeben	2023348				1		
5192650/SPA/000000	Traegerblech links	AW04040 FR	freigegeben	2027244				1	1.5.095-045.0	Traegerblech links
5192651/SPA/000000	Traegerblech rechts	AW04040 FR	freigegeben	2027244				1	1.5.095-046.0	Traegerblech rechts
5192652/SPA/000000	Querstrebe Mitte Traeger	AW04040 FR	freigegeben	2023348				1	1.5.095-047.0	Querstrebe Mitte Traeger
5192653/SPA/000000	Querstrebe Traeger	AW04040 FR	freigegeben	2023348				1	1.5.095-048.0	Querstrebe Traeger
5192654/SPA/000000	Traegerblech vorne	AW04040 FR	freigegeben	2027244				2	2.095-049.0	Traegerblech vorne
5192655/SPA/000000	Aufnahmebuchse Drehpunkt	AW02892 FR	freigegeben	2023348				4	4.5.111-192.0	Aufnahmebuchse Drehpunkt
5192656/SPA/000000	Zylinderbuchse Oben	AW02892 FR	freigegeben	2026634				4	4.5.111-193.0	Zylinderbuchse oben
5116225/SPA/000000	Schweissmutter DIN 929 M8	AW02468 FR	freigegeben	2014918				12	7.311-503.0	Schweissmutter M 8-ST DIN 929
5192678/SPR/000001	Auswurfschacht Gehäuse kpl.	AW04040 FR	freigegeben	2026634				1	1.4.058-187.0	Auswurfschacht Gehäuse kpl.
5192673/SPA/500000	Dummy Ursprung Auswurf	AW02892 FR	freigegeben	2023348				1		
5192674/SPA/000000	Gehäuse Blechteil Auswerfer	AW04040 FR	freigegeben	2026634				2	5.095-050.0	Gehäuse Blechteil Auswerfer
5192675/SPA/000000	Bogen Auswerfer	AW04040 FR	freigegeben	2026634				1	1.5.095-051.0	Bogen Auswerfer
5116222/SPA/000000	Schweissmutter DIN 929 M6	AW02468 FR	freigegeben	2014918				16	7.311-502.0	Schweissmutter M 6-ST DIN 929
5192683/SPA/000000	Wasserprallblech	AW04040 FR	freigegeben	2026634				1	1.5.095-063.0	Wasserprallblech
5206482/SPA/000000	Saugrohr Auswurfschacht	AW04040 FR	freigegeben	2026634				1	1.5.095-161.0	Saugrohr oben
5206559/SPA/000000	Blechteil Rahmen Gitterrost	AW04040 FR	freigegeben	2026634				1	1.5.095-165.0	Blechteil Rahmen Gitterrost
5206716/SPA/000000	Blechteil Knotenblech	AW04040 FR	freigegeben	2026634				4	5.095-164.0	Blechteil Knotenblech
5192672/SPR/000001	Saugrohr kpl.	AW04040 FR	freigegeben	2026634				1	1.4.058-198.0	Saugrohr kpl.
5192670/SPA/000000	Saugrohr	AW04040 FR	freigegeben	2026634				1	1.5.095-054.0	Saugrohr
5192671/SPA/000000	Rohrabchluss	AW04040 FR	freigegeben	2026634				1	1.5.095-055.0	Rohrabschluss
5192646/SPR/000000	Deckelblech kpl.	AW02892 FR	freigegeben	2023348				1	1.4.058-189.0	Deckelblech kpl.

Implementation Part Management

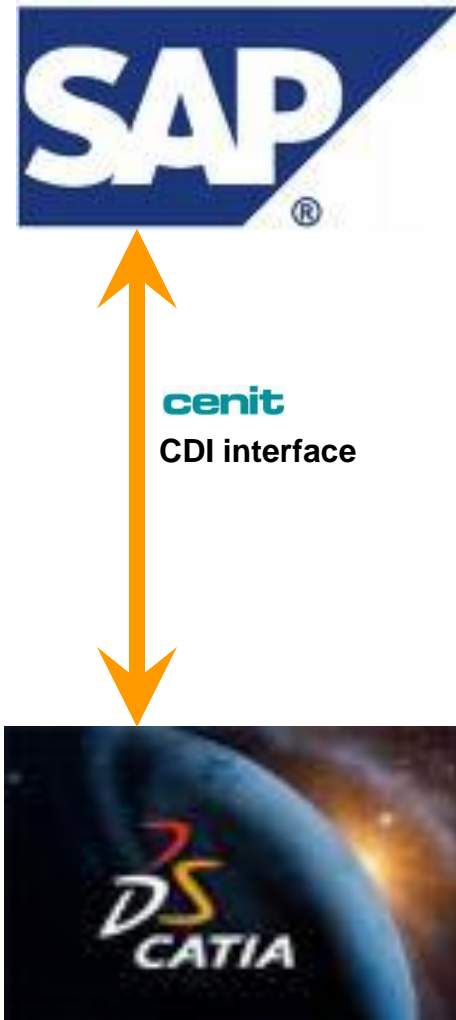

PART
SOLUTIONS

Implementation New Application of 3-D Model

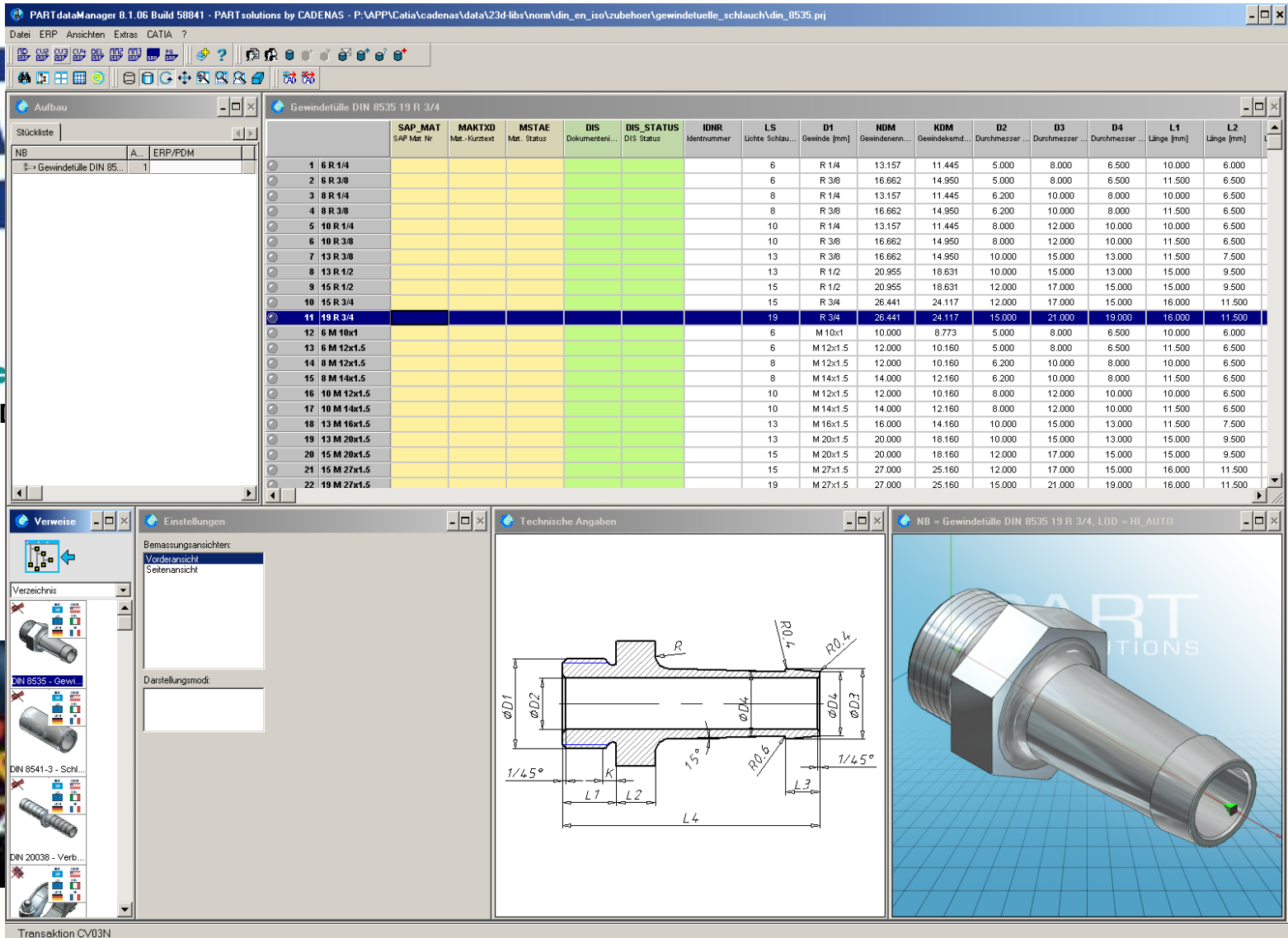

The screenshot displays the PRTdataManager 8.1.06 interface. The main window shows a table of parts with columns for SAP_MAT, MAKTXD, MSTAE, DIS, DIS_STATUS, IDNR, LS, D1, NDM, KDM, D2, D3, D4, L1, and L2. The table lists 22 different part variants, with the 11th variant (19 R 3/4) highlighted in blue. Below the table, there are three panels: 'Verweise' (References) showing a list of parts, 'Einstellungen' (Settings) for view and display modes, and 'Technische Angaben' (Technical Data) showing a 3D model and a technical drawing of a threaded part with dimensions like $\phi D1$, $\phi D2$, $\phi D4$, $\phi D3$, $\phi D4$, $\phi D3$, $1/4.5^\circ$, 15° , $R0.6$, $R0.4$, $R0.4$, R , $L1$, $L2$, and $L4$.

	SAP_MAT	MAKTXD	MSTAE	DIS	DIS_STATUS	IDNR	LS	D1	NDM	KDM	D2	D3	D4	L1	L2
	SAP Mat Nr	Mat.-Kurztext	Mat. Status	Dokumenten...	DIS Status	Identnummer	Lichte Schlu...	Gewinde [mm]	Gewindekenn...	Gewindekenn...	Durchmesser ...	Durchmesser ...	Durchmesser ...	Länge [mm]	Länge [mm]
1	6 R 1/4						6	R 1/4	13.157	11.445	5.000	8.000	6.500	10.000	6.000
2	6 R 3/8						6	R 3/8	16.662	14.950	5.000	8.000	6.500	11.500	6.500
3	8 R 1/4						8	R 1/4	13.157	11.445	6.200	10.000	8.000	10.000	6.500
4	8 R 3/8						8	R 3/8	16.662	14.950	6.200	10.000	8.000	11.500	6.500
5	10 R 1/4						10	R 1/4	13.157	11.445	8.000	12.000	10.000	10.000	6.500
6	10 R 3/8						10	R 3/8	16.662	14.950	8.000	12.000	10.000	11.500	6.500
7	13 R 3/8						13	R 3/8	16.662	14.950	10.000	15.000	13.000	11.500	7.500
8	13 R 1/2						13	R 1/2	20.955	18.631	10.000	15.000	13.000	15.000	9.500
9	15 R 1/2						15	R 1/2	20.955	18.631	12.000	17.000	15.000	15.000	9.500
10	15 R 3/4						15	R 3/4	26.441	24.117	12.000	17.000	15.000	16.000	11.500
11	19 R 3/4						19	R 3/4	26.441	24.117	15.000	21.000	19.000	16.000	11.500
12	6 M 10x1						6	M 10x1	10.000	8.773	5.000	8.000	6.500	10.000	6.000
13	6 M 12x1.5						6	M 12x1.5	12.000	10.160	5.000	8.000	6.500	11.500	6.500
14	8 M 12x1.5						8	M 12x1.5	12.000	10.160	6.200	10.000	8.000	10.000	6.500
15	8 M 14x1.5						8	M 14x1.5	14.000	12.160	6.200	10.000	8.000	11.500	6.500
16	10 M 12x1.5						10	M 12x1.5	12.000	10.160	8.000	12.000	10.000	10.000	6.500
17	10 M 14x1.5						10	M 14x1.5	14.000	12.160	8.000	12.000	10.000	11.500	6.500
18	13 M 16x1.5						13	M 16x1.5	16.000	14.160	10.000	15.000	13.000	11.500	7.500
19	13 M 20x1.5						13	M 20x1.5	20.000	18.160	10.000	15.000	13.000	15.000	9.500
20	15 M 20x1.5						15	M 20x1.5	20.000	18.160	12.000	17.000	15.000	15.000	9.500
21	15 M 27x1.5						15	M 27x1.5	27.000	25.160	12.000	17.000	15.000	16.000	11.500
22	19 M 27x1.5						19	M 27x1.5	27.000	25.160	15.000	21.000	19.000	16.000	11.500

Implementation New Application of 3-D Model

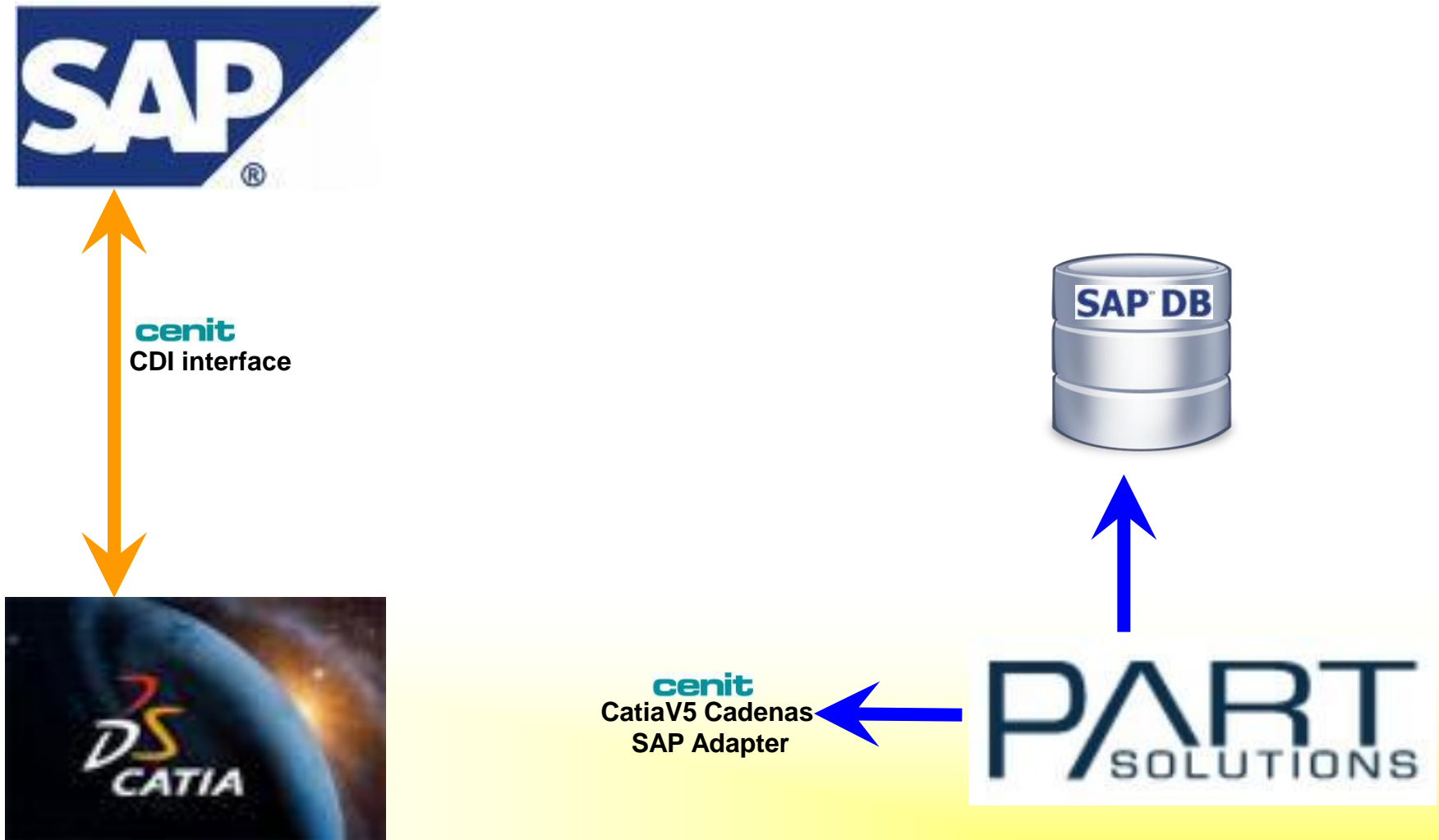

Implementation New Application of 3-D Model

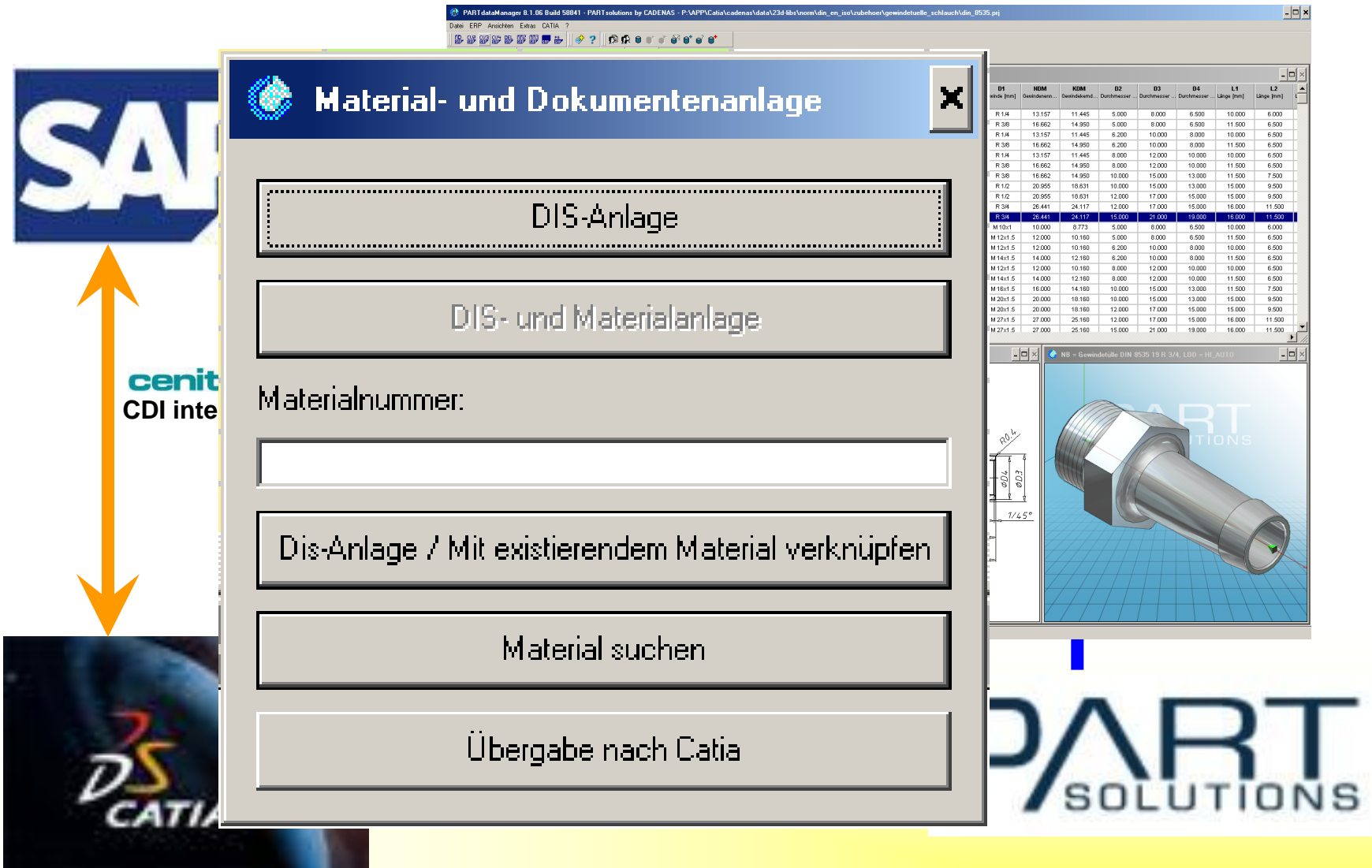

The screenshot shows the PART dataManager 9.1.06 interface. The main menu 'Material- und Dokumentenanlage' is open, displaying several options: 'DIS-Anlage', 'DIS- und Materialanlage', a text input field for 'Materialnummer:', 'Dis-Anlage / Mit existierendem Material verknüpfen', 'Material suchen', and 'Übergabe nach Catia'. To the right, a table lists various part specifications with columns for D1, NDM, KDM, D2, D3, D4, L1, and L2. Below the table, a 3D model of a bolt is shown with technical dimensions: $R0,4$, $\phi D1$, $\phi D2$, and $1/4 5^\circ$. The background features the 'SAI' logo and 'centi CDI inte' text, and the 'PART SOLUTIONS' logo is visible at the bottom right.

D1	NDM	KDM	D2	D3	D4	L1	L2
Stück (mm)	Geänderten.	Geänd.umd.	Durchmesser	Durchmesser	Durchmesser	Länge (mm)	Länge (mm)
R 1/4	13.157	11.445	5.000	8.000	6.500	10.000	6.500
R 3/8	16.662	14.950	5.000	8.000	6.500	11.500	6.500
R 1/4	13.157	11.445	6.200	10.000	8.000	10.000	6.500
R 3/8	16.662	14.950	6.200	10.000	8.000	11.500	6.500
R 1/4	13.157	11.445	8.000	12.000	10.000	10.000	6.500
R 3/8	16.662	14.950	8.000	12.000	10.000	11.500	6.500
R 3/8	16.662	14.950	10.000	15.000	13.000	11.500	7.500
R 1/2	20.955	18.631	10.000	15.000	13.000	15.000	9.500
R 1/2	20.955	18.631	12.000	17.000	15.000	15.000	9.500
R 3/4	25.441	24.117	12.000	17.000	15.000	15.000	11.500
R 3/4	25.441	24.117	15.000	20.000	18.000	18.000	11.500
M10x1	10.000	8.773	5.000	8.000	6.500	10.000	6.000
M12x1.5	12.000	10.160	5.000	8.000	6.500	11.500	6.500
M12x1.5	12.000	10.160	6.200	10.000	8.000	10.000	6.500
M14x1.5	14.000	12.160	6.200	10.000	8.000	11.500	6.500
M12x1.5	12.000	10.160	8.000	12.000	10.000	10.000	6.500
M14x1.5	14.000	12.160	8.000	12.000	10.000	11.500	6.500
M16x1.5	16.000	14.160	10.000	15.000	13.000	11.500	7.500
M20x1.5	20.000	18.160	10.000	15.000	13.000	15.000	9.500
M20x1.5	20.000	18.160	12.000	17.000	15.000	15.000	9.500
M27x1.5	27.000	25.160	12.000	17.000	15.000	18.000	11.500
M27x1.5	27.000	25.160	15.000	21.000	19.000	18.000	11.500

Implementation New Application of 3-D Model

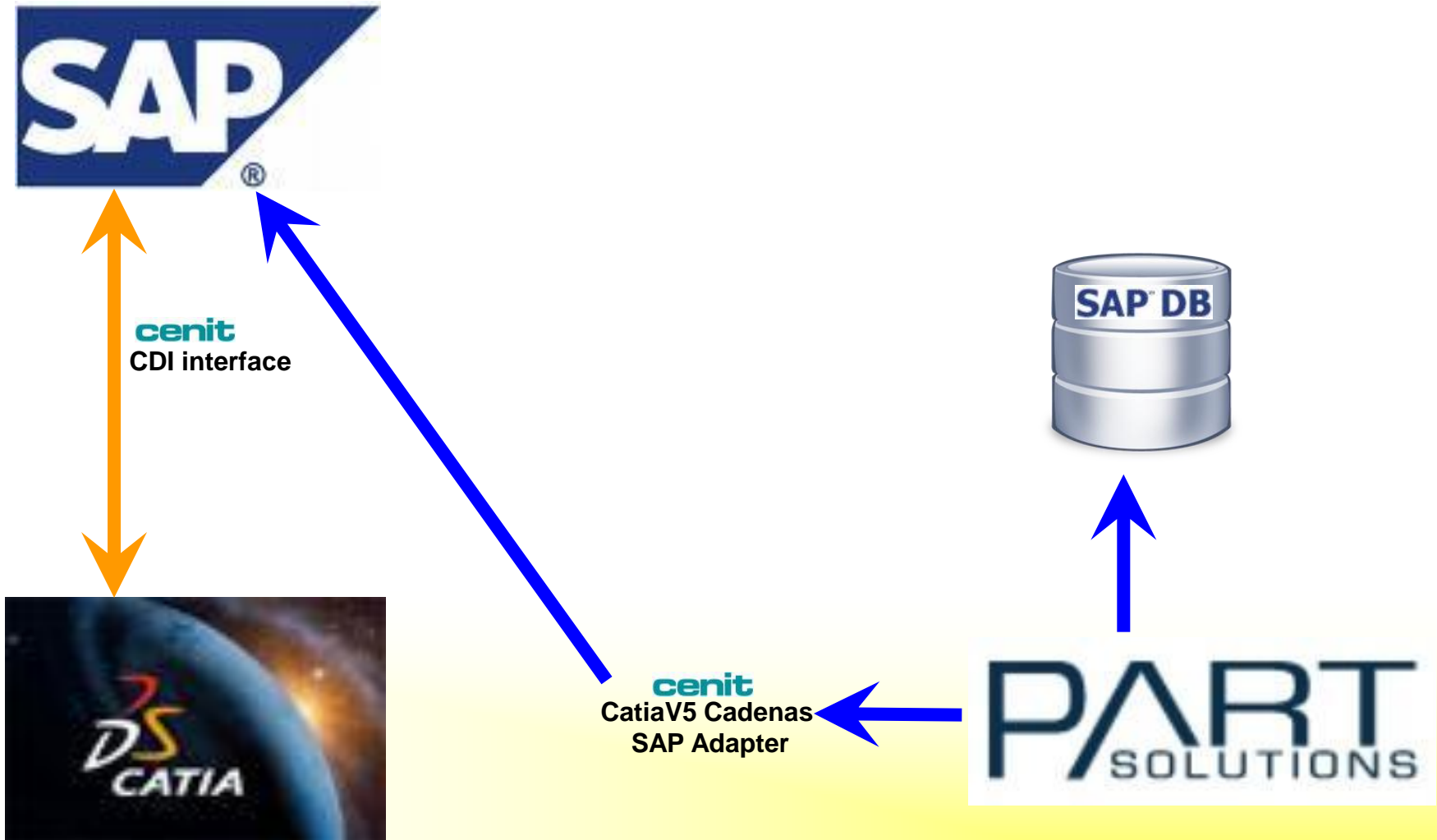

Implementation New Application of 3-D Model

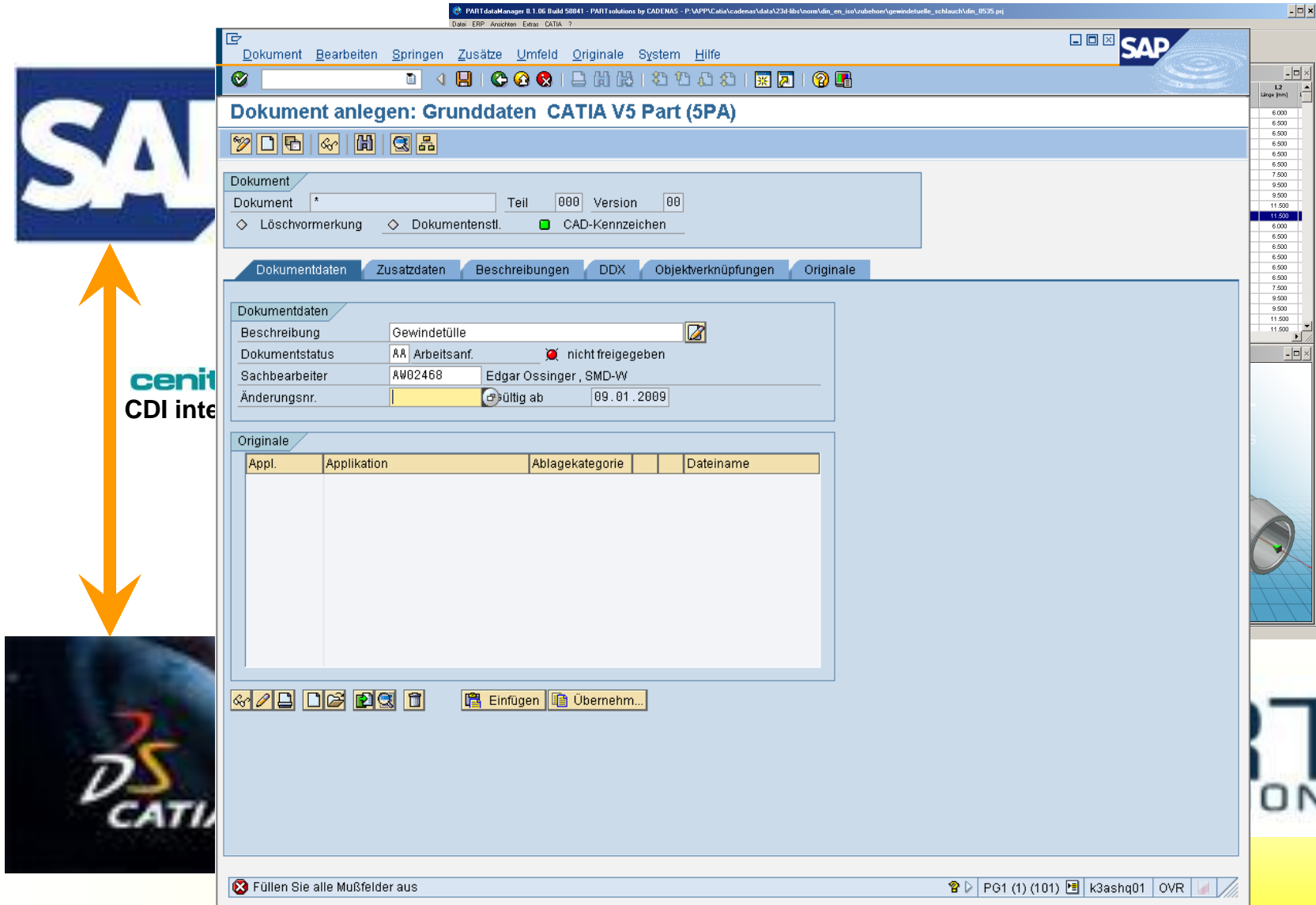

The screenshot shows the SAP data manager interface for creating a document for a CATIA V5 Part (5PA). The window title is "PART dataManager 9.1.06 Build 50841 - PART solutions by CADENAS - P:\APP\Cad\cadenas\data\23d\5b\form\ldm_en_iso\zubehoe\gewindetulle_schlauch\ldm_0525.ppt". The main window title is "Dokument anlegen: Grunddaten CATIA V5 Part (5PA)".

Annotations on the left side include:

- A large blue "SAP" logo.
- An orange double-headed arrow pointing up and down.
- The text "centi CDI inte" (partially visible).
- A dark image with "DS CATIA" text.

The interface shows the following fields and data:

Dokument

Dokument * Teil 000 Version 00

Löschvormerkung Dokumentenstl. CAD-Kennzeichen

Dokumentdaten

Beschreibung Gewindetülle

Dokumentstatus AA Arbeitsanf. nicht freigegeben

Sachbearbeiter AW02468 Edgar Ossinger, SMD-W

Änderungsnr. gültig ab 09.01.2009

Originale

Appl.	Applikation	Ablagekategorie	Dateiname

At the bottom, there is a status bar with the message "Füllen Sie alle Mußfelder aus" and a navigation bar showing "PG1 (1) (101) k3ashq01 OVR".

Implementation New Application of 3-D Model

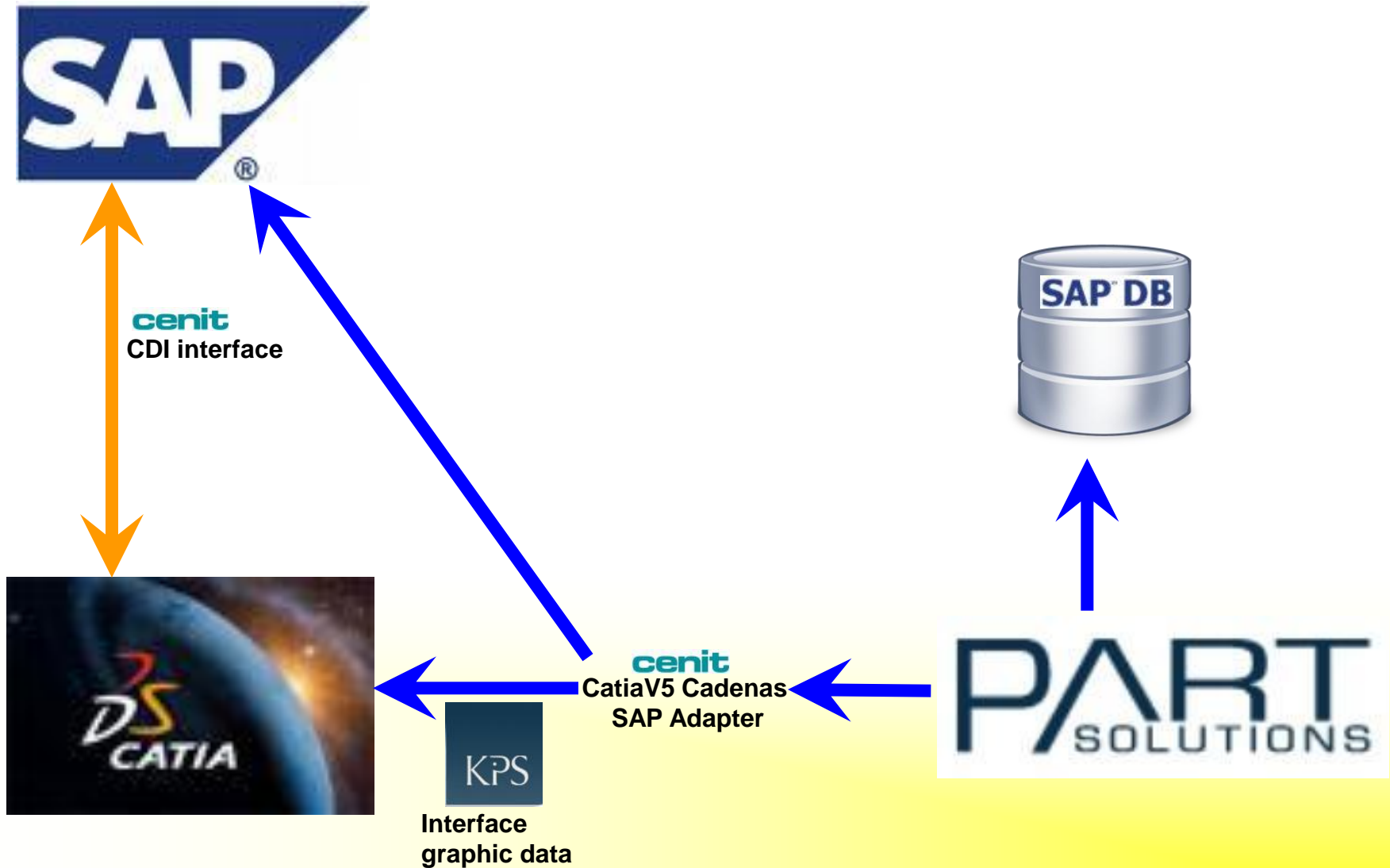

Implementation New Application of 3-D Model

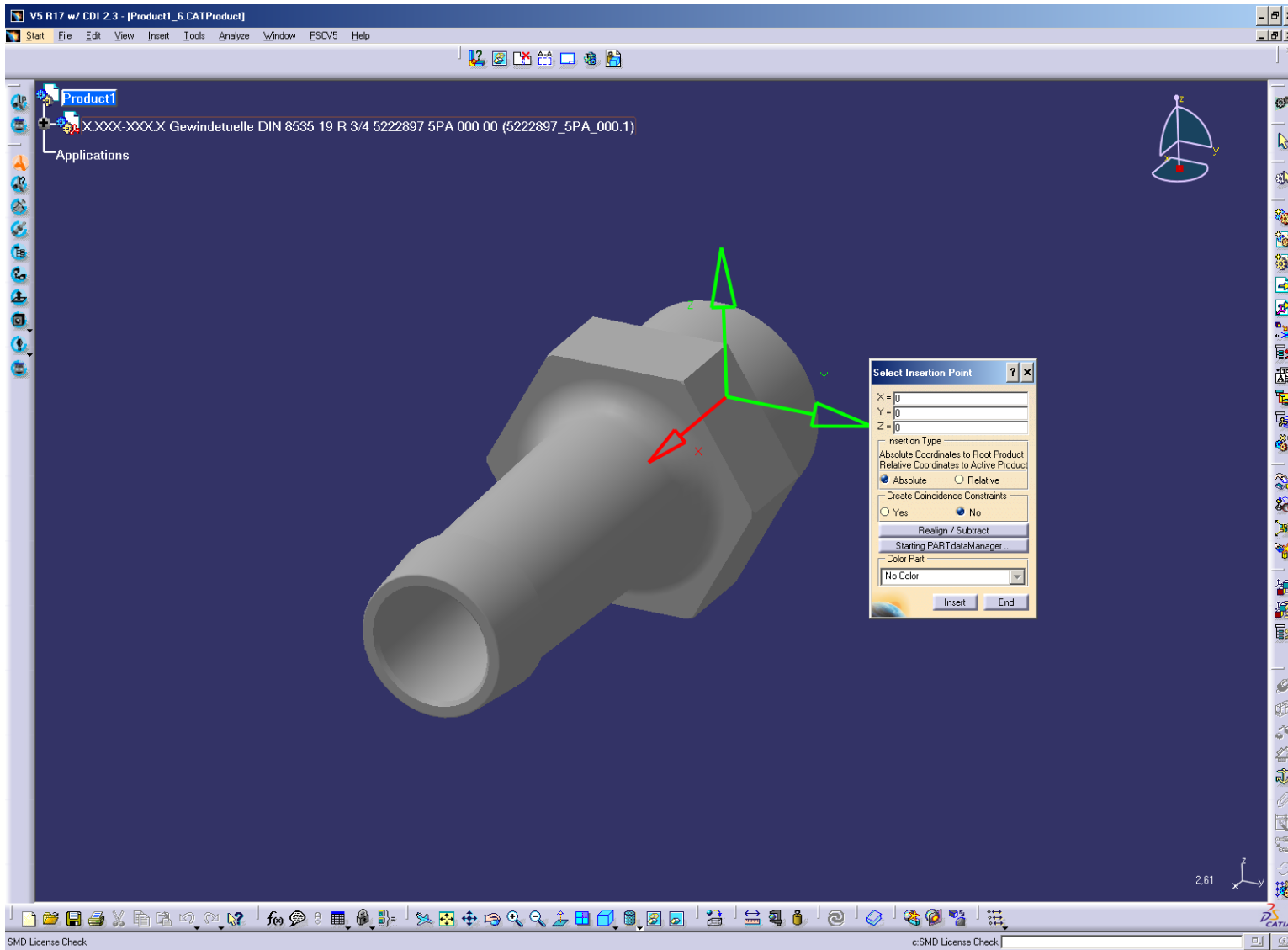

graphic data

Implementation New Application of 3-D Model

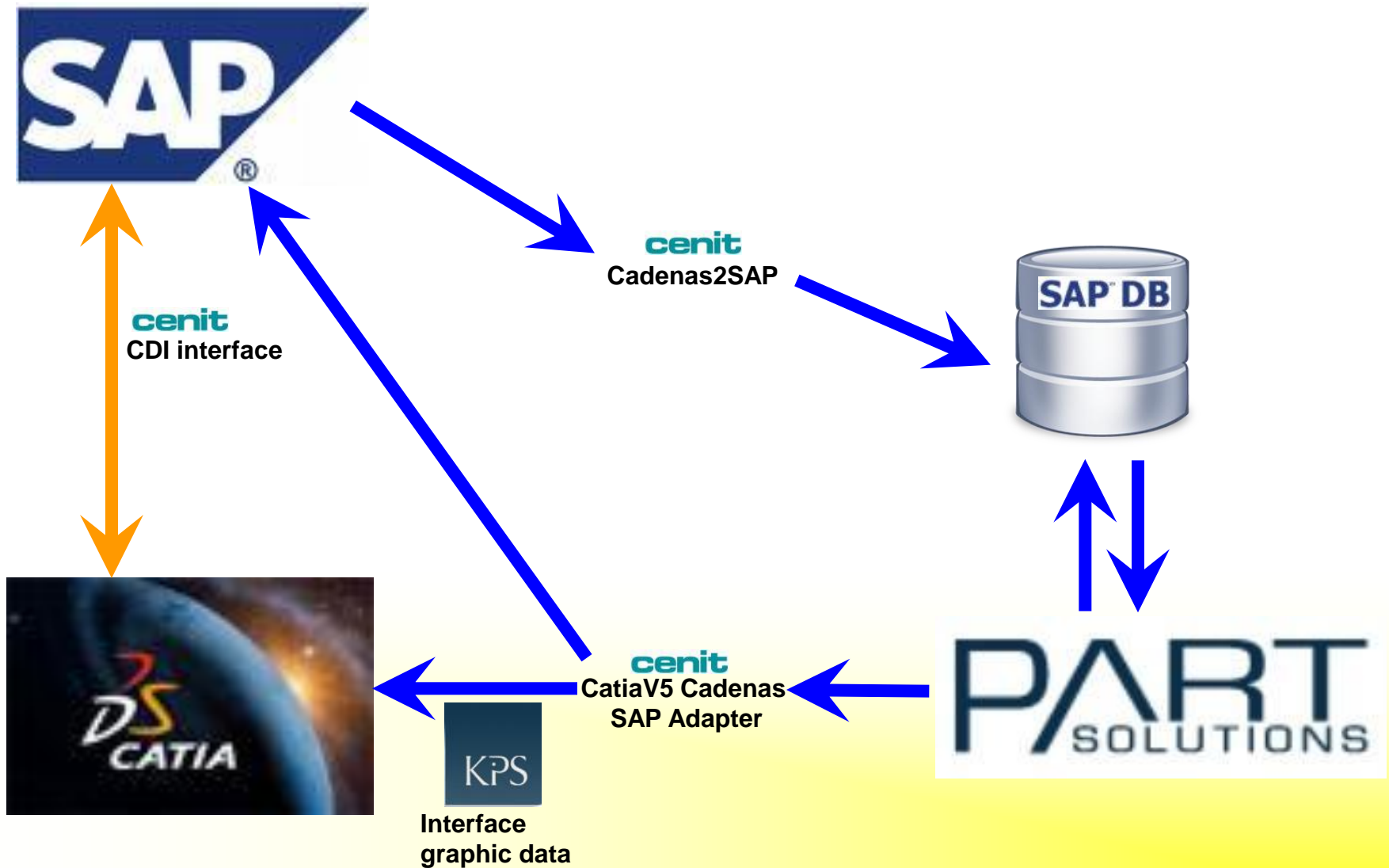

Implementation New Application of 3-D Model

PARTdataManager 8.1.06 Build 58841 - PART solutions by CADENAS - P:\APP\Catia\cadenas\data\23d-libs\norm\din_en_iso\zubehoer\gewindetuelle_schlauch\din_8535.pj

File ERP Ansichten Extras CATIA ?

Aufbau

Stückliste

	SAP_MAT SAP Mat. Nr.	MAKTXD Mat.-Kürzext	MSTAE Mat. Status	DIS Dokumentenreferenz	DIS_STATUS DIS Status	IDNR Identnummer	LS Lichte Schäu...	D1 Gewinde [mm]	NOM Gewindenenn...	KDM Gewindekemd...	D2 Durchmesser ...	D3 Durchmesser ...	D4 Durchmesser ...	L1 Länge [mm]	Länge
1	6 R 1/4						6	R 1/4	13.157	11.445	5.000	8.000	6.500	10.000	6
2	6 R 3/8						6	R 3/8	16.662	14.950	5.000	8.000	6.500	11.500	6
3	8 R 1/4						8	R 1/4	13.157	11.445	6.200	10.000	8.000	10.000	6
4	8 R 3/8						8	R 3/8	16.662	14.950	6.200	10.000	8.000	11.500	6
5	10 R 1/4						10	R 1/4	13.157	11.445	8.000	12.000	10.000	10.000	6
6	10 R 3/8						10	R 3/8	16.662	14.950	8.000	12.000	10.000	11.500	6
7	13 R 3/8						13	R 3/8	16.662	14.950	10.000	15.000	13.000	11.500	7
8	13 R 1/2						13	R 1/2	20.955	18.631	10.000	15.000	13.000	15.000	9
9	15 R 1/2						15	R 1/2	20.955	18.631	12.000	17.000	15.000	15.000	9
10	15 R 3/4						15	R 3/4	26.441	24.117	12.000	17.000	15.000	16.000	11
11	19 R 3/4			5222897_SPA_000_00	AA		19	R 3/4	26.441	24.117	15.000	21.000	19.000	16.000	11
12	6 M 10x1						6	M 10x1	10.000	8.773	5.000	8.000	6.500	10.000	6
13	6 M 12x1.5						6	M 12x1.5	12.000	10.160	5.000	8.000	6.500	11.500	6
14	8 M 12x1.5						8	M 12x1.5	12.000	10.160	6.200	10.000	8.000	10.000	6
15	8 M 14x1.5						8	M 14x1.5	14.000	12.160	6.200	10.000	8.000	11.500	6
16	10 M 12x1.5						10	M 12x1.5	12.000	10.160	8.000	12.000	10.000	10.000	6
17	10 M 14x1.5						10	M 14x1.5	14.000	12.160	8.000	12.000	10.000	11.500	6
18	13 M 16x1.5						13	M 16x1.5	16.000	14.160	10.000	15.000	13.000	11.500	7
19	13 M 20x1.5						13	M 20x1.5	20.000	18.160	10.000	15.000	13.000	15.000	9
20	15 M 20x1.5						15	M 20x1.5	20.000	18.160	12.000	17.000	15.000	15.000	9
21	15 M 27x1.5						15	M 27x1.5	27.000	25.160	12.000	17.000	15.000	16.000	11
22	19 M 27x1.5						19	M 27x1.5	27.000	25.160	15.000	21.000	19.000	16.000	11

Verweise

Einstellungen

Bemessungsansichten:
Vorderansicht
Seitenansicht

Darstellungsmodi:

Technische Angaben

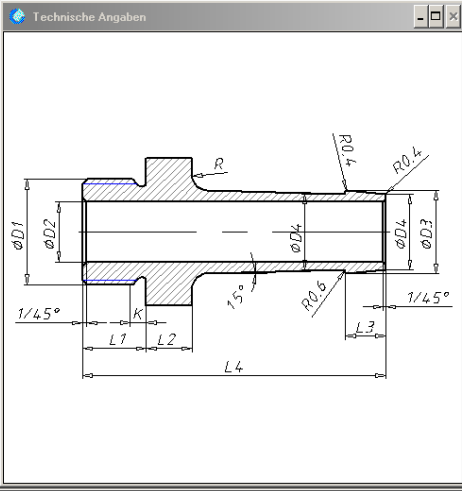

NB - Gewindetülle DIN 8535 6 M 10x1, LOD - HI_AUTO

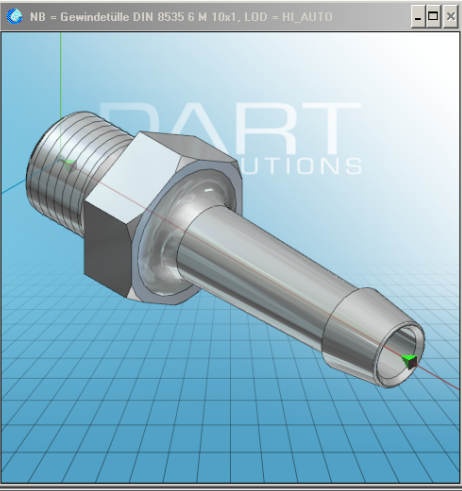

Linkmanager aufrufen

Implementation Change Data

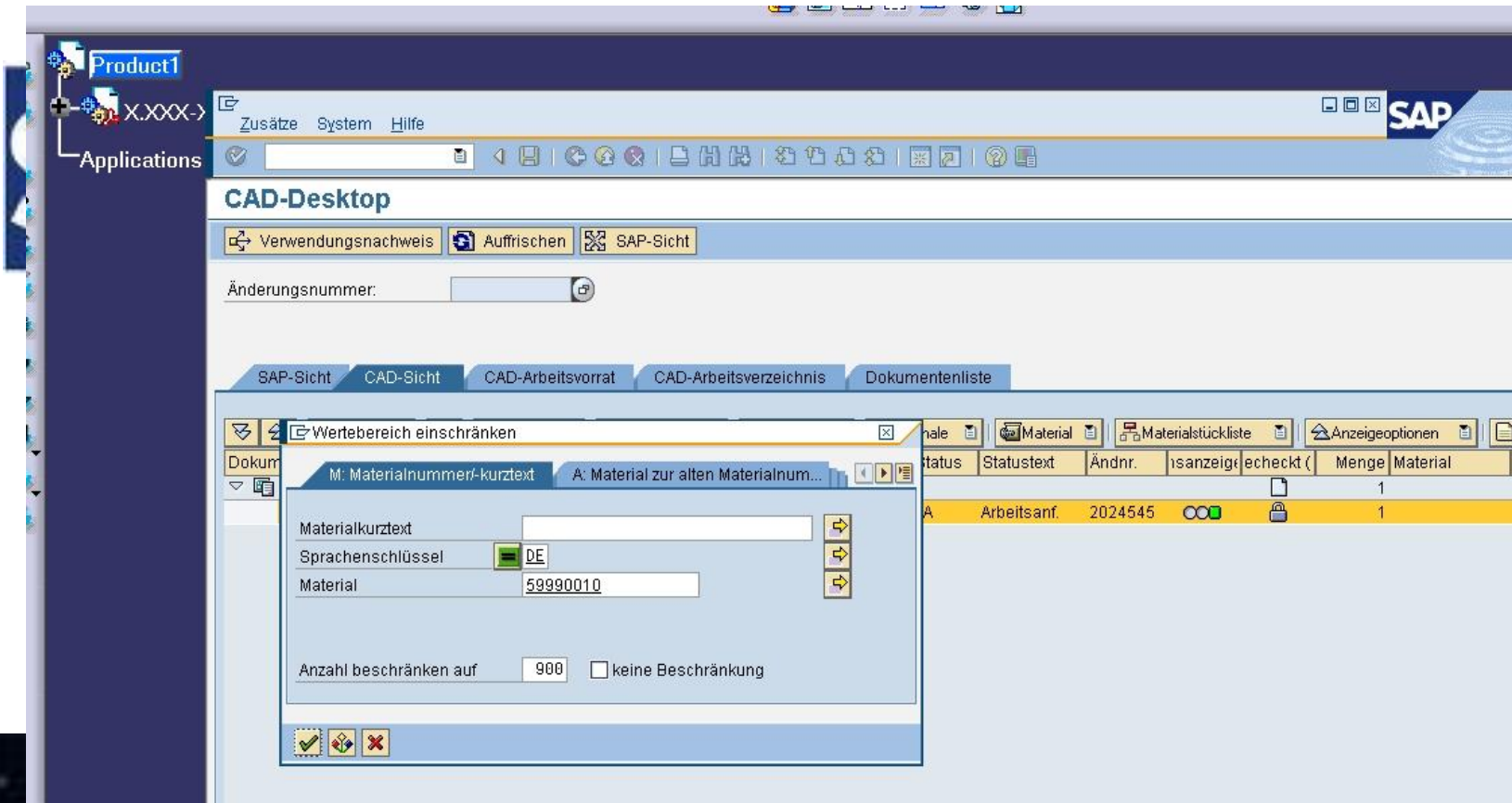

Implementation Change Data

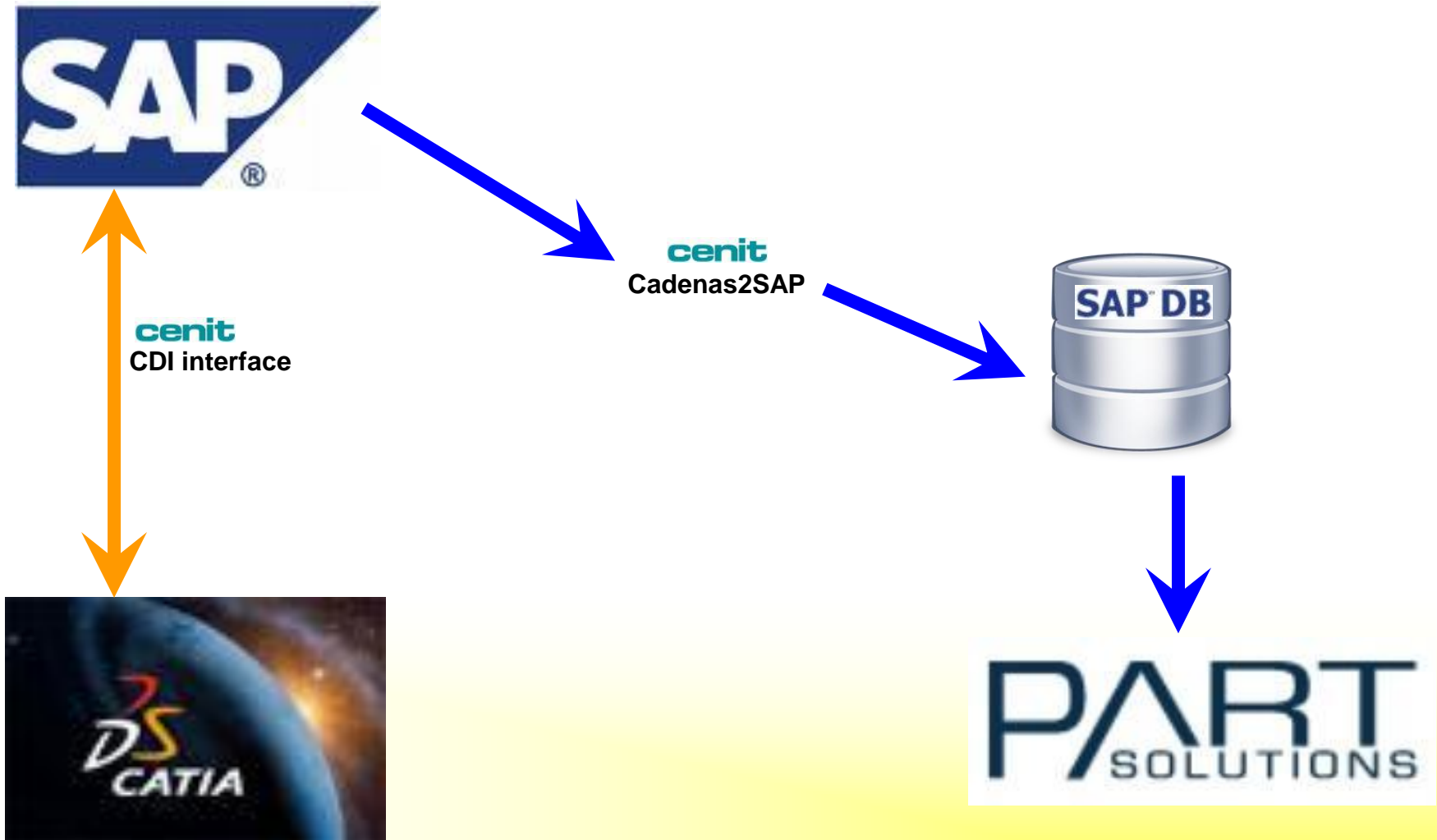

Implementation Change Data

PARTdataManager 8.1.06 Build 58841 - PARTsolutions by CADENAS - P:\APP\Calia\cadenas\data\23d-lib\norm\din_en_iso\zubehoer\gewindetuelle_schlauch\din_8535.pj

Datei ERP Ansichten Extras CATIA ?

Aufbau Gewindetülle DIN 8535 6 M 10x1

NB	SAP_MAT	MAKTXD	MSTAE	DIS	DIS_STATUS	IDNR	LS	D1	NDM	KDM	D2	D3	D4	L1
	SAP Mat Nr	Mat.-Kurztext	Mat. Status	Dokumenteninforatz	DIS Status	Identnummer	Lichte Schla...	Gewinde [mm]	Gewindenenn...	Gewindekern...	Durchmesser ...	Durchmesser ...	Durchmesser ...	Länge [m]
1	6 R 1.4						6	R 1.4	13.157	11.445	5.000	8.000	6.500	10.0
2	6 R 3.8						6	R 3.8	16.662	14.950	5.000	8.000	6.500	11.5
3	8 R 1.4						8	R 1.4	13.157	11.445	6.200	10.000	8.000	10.0
4	8 R 3.8						8	R 3.8	16.662	14.950	6.200	10.000	8.000	11.5
5	10 R 1.4						10	R 1.4	13.157	11.445	8.000	12.000	10.000	10.0
6	10 R 3.8						10	R 3.8	16.662	14.950	8.000	12.000	10.000	11.5
7	13 R 3.8						13	R 3.8	16.662	14.950	10.000	15.000	13.000	11.5
8	13 R 1.2						13	R 1.2	20.955	18.631	10.000	15.000	13.000	15.0
9	15 R 1.2						15	R 1.2	20.955	18.631	12.000	17.000	15.000	15.0
10	15 R 3/4						15	R 3/4	26.441	24.117	12.000	17.000	15.000	18.0
11	19 R 3/4	5.999-001.0	Schlauchsnippel R 3/4"-1.4301	F	5222897_5PA_000_00	AA	19	R 3/4	26.441	24.117	15.000	21.000	19.000	18.0
12	6 M 10x1						6	M 10x1	10.000	8.773	5.000	8.000	6.500	10.0
13	6 M 12x1.5						6	M 12x1.5	12.000	10.160	5.000	8.000	6.500	11.5
14	8 M 12x1.5						8	M 12x1.5	12.000	10.160	6.200	10.000	8.000	10.0
15	8 M 14x1.5						8	M 14x1.5	14.000	12.160	6.200	10.000	8.000	11.5
16	10 M 12x1.5						10	M 12x1.5	12.000	10.160	8.000	12.000	10.000	10.0

Verweise **Einstellungen** **Technische Angaben** NB - Gewindetülle DIN 8535 6 M 10x1, LOD - HI_AUTO

Verzeichnis

DIN 8535 - Gewi...

DIN 8541-3 - Schl...

DIN 20038 - Verb...

Darstellungsmodi

Dimmungsansichten:
Vorderansicht
Seitenansicht

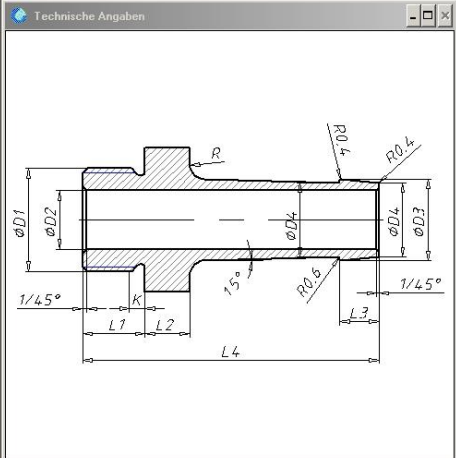
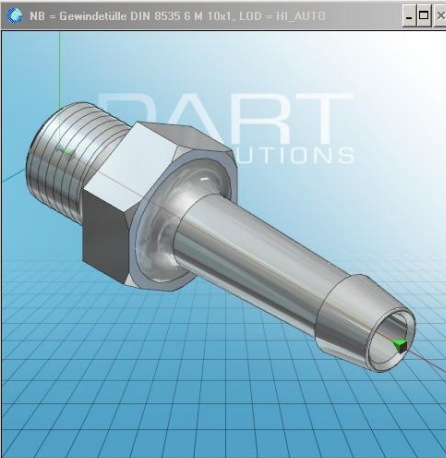



Gewindetülle 19.06.2007 #16 ew02468 - Administrator 100.0 User

Implementation Reuse

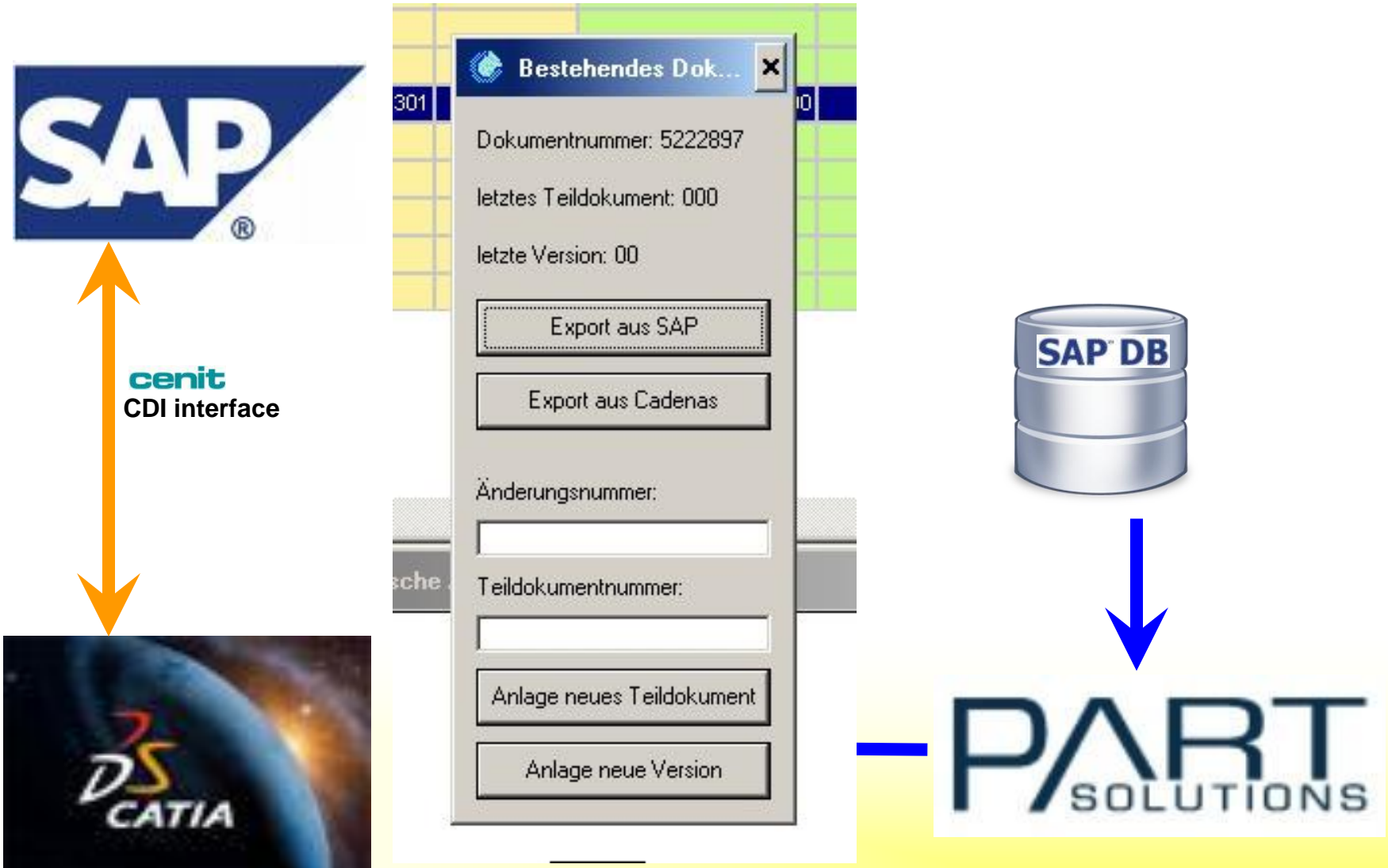

Implementation Reuse



Implementation Reuse

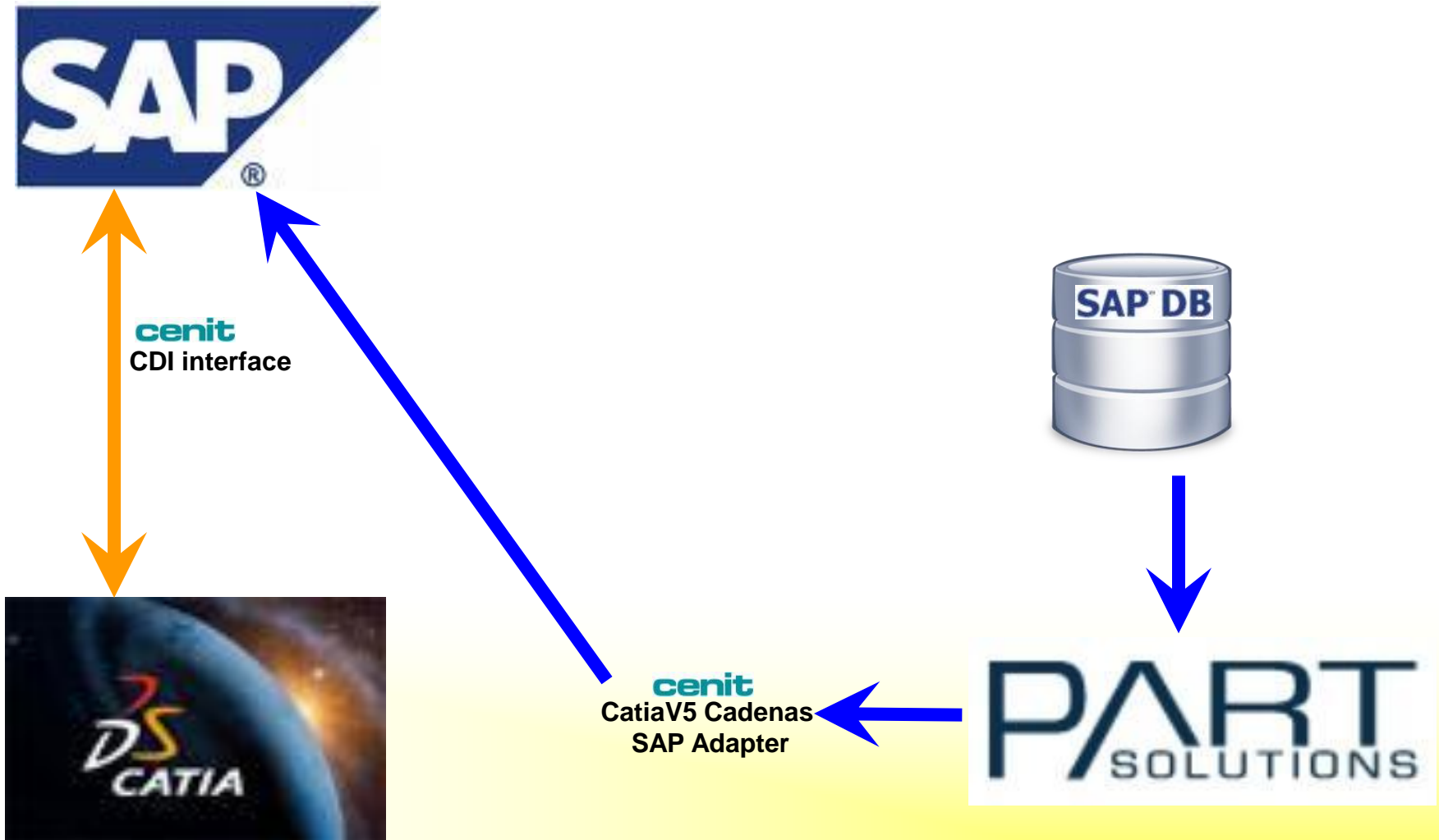

Implementation Reuse

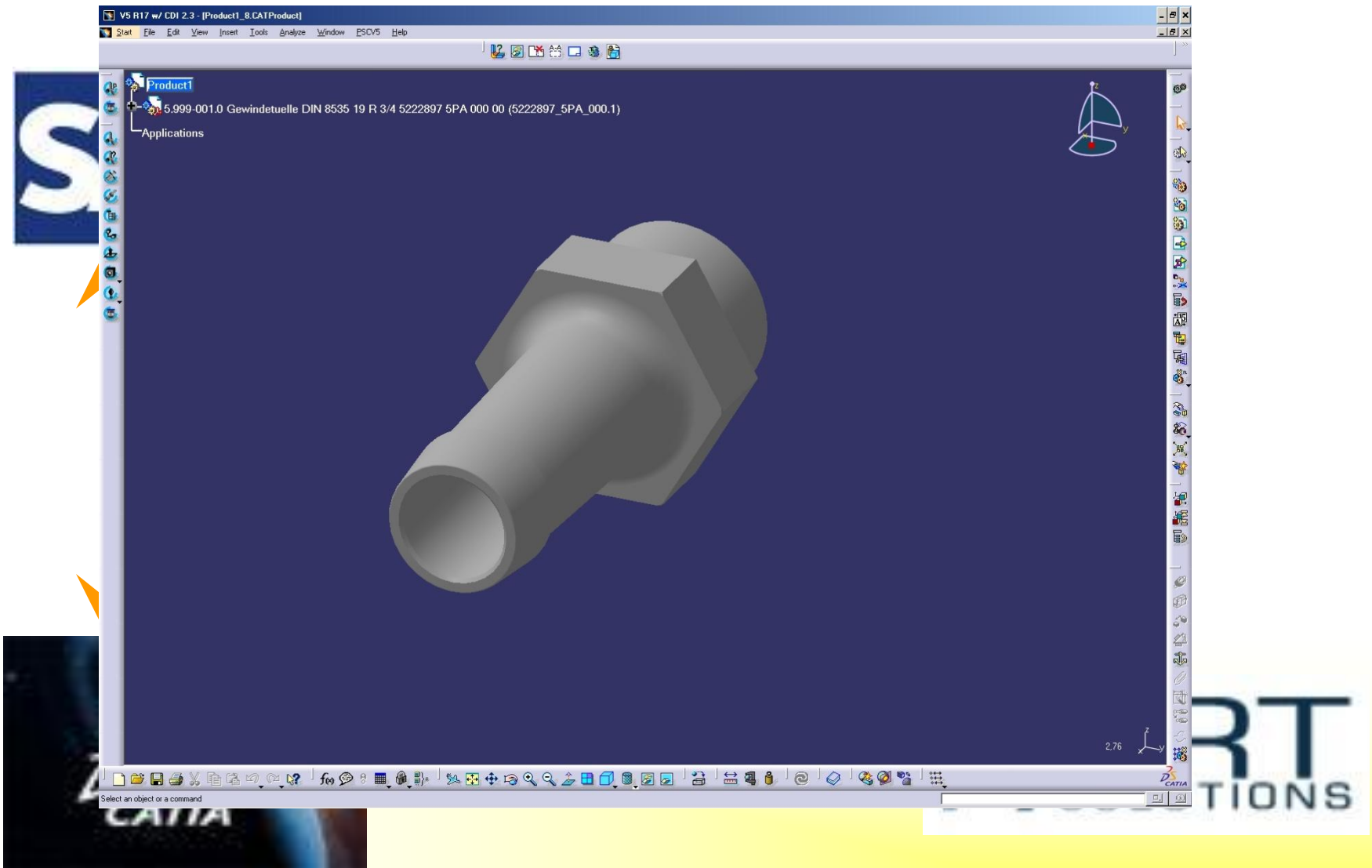

Classification History

- 1988 Start of assembly of classification (Mantext IBM)
- 1989 Introduction of program OSAM (IBM)
- 1991 Update on ESAM (USU software)
- 1993 Update on ESAM II (USU software)
Introduction Cadselect under CADAM (Festo)
- 1999 Introduction SAP classification
- 2006 Introduction PARTsolutions
- 2009 Introduction classification in PARTsolutions

→ Amount of material numbers

~~240~~ 000

Specialty
Integration of factories
in America

Implementation Classification

Suche Bearbeiten Springen Bewertung Zusätze Umfeld System Hilfe

Objekte in Klassen suchen

Suche in Einstiegsklasse Suche auch in Unterklassen Nachselektion

Klassenstruktur

Klassifizierung	Kurztext
001 0305	Kopf- und Maschinenschrauben
001 030501	Schrauben mit metrischem Gewinde
001 03050100	Sechskantschrauben
001 03050101	6kt-Schrauben, Gewinde bis Kopf ISO 4017
001 03050101	6kt-Schrauben mit Schaft nach ISO 4014
001 03050102	6kt-Schrauben nach EN 14399-4
001 03050103	6kt-Schrauben mit Flansch EN 1665
001 03050109	6kt-Schrauben mit Schaft > Gewinde
001 0305011	Sechskantschrauben mit Feingewinde
001 03050110	6kt-Schrauben mit Feingewinde ISO 8676
001 03050115	Kugelbuntdschrauben DIN 74361-2 Form G
001 030502	Zylinderkopfschrauben
001 030503	Linienkopfschrauben
001 030504	Flachkopfschrauben

Einstiegsklasse

Merkmale

Allgemein

DIN	Merkmalebezeichnung	Wert
A83	Gewindenenddurchmes...	
B	Nennlänge	
C1	Gewindelänge	
H1	Festigkeitsklasse	
H2	Werkstoff	
Y	Oberflächenschutz	
Y	eCl@ss 6.2 Klassifikation	
Z	Materialstatus	

7.304-125.0 in Klasse 03050101

Objekt: 00000000073041250

Merkmalebezeichnung	Merkmalewert
Gewindekennbuchstabe	M
Gewindenenddurchmesser	8,0 mm
Nennlänge	85,00 mm
Gewindelänge	22,00 mm
Schlüsselweite	13,0 mm
Kopfhöhe	5,30 mm
Produktklasse	A
Festigkeitsklasse	8.8
Werkstoff	Stahl
Oberflächenschutz	A2E (verzinkt, blank)
eCl@ss 6.2 Klassifikation	23-11-01-01
Materialstatus	F

Viewer Navigation Werkzeuge

KL2/5008000/001/03

03050101

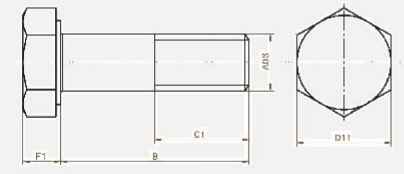



KÄRCHER

Objekt	Bezeichnung	Z Materialstatus	H1 Festigkeitsk	Y eCl@ss 6.2 Klassifikation
7.304-252.0	6kt-Schraube M5x12-A4-70 ISO 4014	IE	A4-70	23-11-01-01
7.304-239.0	6kt-Schraube M 6x30-8.8-A2E ISO 4014	FE	8.8	23-11-01-01
7.304-085.0	6kt-Schraube M6x55-8.8-A2E ISO 4014	F	8.8	23-11-01-01
7.304-089.0	6kt-Schraube M 6x60-8.8-A2E ISO 4014	F	8.8	23-11-01-01
7.304-232.0	6kt-Schr. M 6X 65-A4-70 ISO 4014	F	A4-70	23-11-01-01
7.304-087.0	6kt-Schraube M 6x70-8.8-A2E ISO 4014	FE	8.8	23-11-01-01
7.304-233.0	6kt-Schr. M 6X 70-A4-70 ISO 4014	F	A4-70	23-11-01-01
7.304-107.0	6kt-Schraube M 8x45-8.8-A2E ISO 4014	FE	8.8	23-11-01-01
7.304-280.0	6kt-Schraube M8x45-CU 2 ISO 4014	F	CU2	23-11-01-01
7.304-031.0	6kt-Schraube M8x55-8.8-A2E ISO 4014	F	8.8	23-11-01-01
7.304-096.0	6kt-Schraube M8x60-8.8-A2E ISO 4014	F	8.8	23-11-01-01
7.304-097.0	6kt-Schraube M8x70-8.8-A2E ISO 4014	F	8.8	23-11-01-01
7.304-075.0	6kt-Schraube M 8x75-8.8-A2E ISO 4014	FE	8.8	23-11-01-01
7.304-098.0	6kt-Schraube M8x80-8.8-A2E ISO 4014	F	8.8	23-11-01-01
7.304-125.0	6kt-Schraube M8x85-8.8-A2E ISO 4014	F	8.8	23-11-01-01
7.304-099.0	6kt-Schraube M 8x90-8.8-A2E ISO 4014	F	8.8	23-11-01-01
7.304-078.0	6kt-Schraube M 8x180-A2-70 ISO 4014	V	A2-70	23-11-01-01
7.304-127.0	6kt-Schraube M10x60-8.8-A2E ISO 4014	FG	8.8	23-11-01-01
7.304-128.0	6kt-Schr. M10X 65-8.8-A2E ISO 4014	F	8.8	23-11-01-01
7.304-126.0	6kt-Schraube M10x80-8.8-A2E ISO 4014	FE	8.8	23-11-01-01
7.304-124.0	6kt-Schraube M10x100-5.6-A2K ISO 4014	F	5.6	23-11-01-01
7.304-117.0	6kt-Schraube M10x110-8.8-A3E ISO 4014	F	8.8	23-11-01-01
7.304-123.0	6kt-Schraube M10x120-8.8-A3E ISO 4014	F	8.8	23-11-01-01
7.304-130.0	6kt-Schr. M10x140-8.8-A3E ISO 4014	F	8.8	23-11-01-01

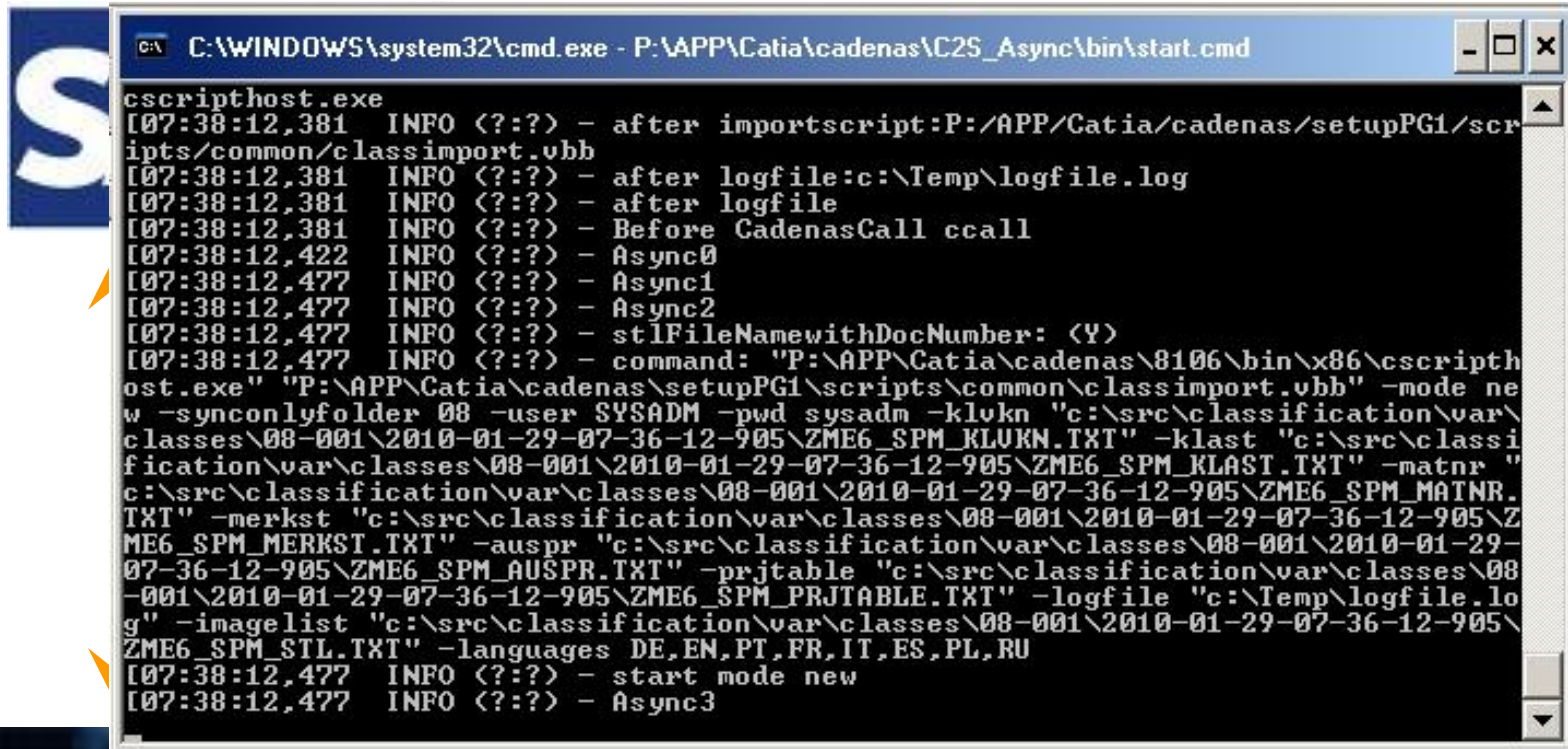

Implementation Classification



```
C:\WINDOWS\system32\cmd.exe - P:\APP\Catia\cadenas\C2S_Async\bin\start.cmd

cscript.exe
[07:38:12,381 INFO (?:?) - after importsript:P:/APP/Catia/cadenas/setupPG1/scripts/common/classimport.vbb
[07:38:12,381 INFO (?:?) - after logfile:c:\Temp\logfile.log
[07:38:12,381 INFO (?:?) - after logfile
[07:38:12,381 INFO (?:?) - Before CadenasCall ccall
[07:38:12,422 INFO (?:?) - Async0
[07:38:12,477 INFO (?:?) - Async1
[07:38:12,477 INFO (?:?) - Async2
[07:38:12,477 INFO (?:?) - stlFileNameWithDocNumber: (Y)
[07:38:12,477 INFO (?:?) - command: "P:\APP\Catia\cadenas\8106\bin\x86\cscript.exe" "P:\APP\Catia\cadenas\setupPG1\scripts\common\classimport.vbb" -mode new -synonlyfolder 08 -user SYSADM -pwd sysadm -klok "c:\src\classification\var\classes\08-001\2010-01-29-07-36-12-905\ZME6_SPM_KLUKN.TXT" -klast "c:\src\classification\var\classes\08-001\2010-01-29-07-36-12-905\ZME6_SPM_KLAST.TXT" -matnr "c:\src\classification\var\classes\08-001\2010-01-29-07-36-12-905\ZME6_SPM_MATNR.TXT" -merkst "c:\src\classification\var\classes\08-001\2010-01-29-07-36-12-905\ZME6_SPM_MERKST.TXT" -auspr "c:\src\classification\var\classes\08-001\2010-01-29-07-36-12-905\ZME6_SPM_AUSPR.TXT" -prjtable "c:\src\classification\var\classes\08-001\2010-01-29-07-36-12-905\ZME6_SPM_PRJTABLE.TXT" -logfile "c:\Temp\logfile.log" -imagelist "c:\src\classification\var\classes\08-001\2010-01-29-07-36-12-905\ZME6_SPM_STL.TXT" -languages DE,EN,PT,FR,IT,ES,PL,RU
[07:38:12,477 INFO (?:?) - start mode new
[07:38:12,477 INFO (?:?) - Async3
```



Implementation Classification

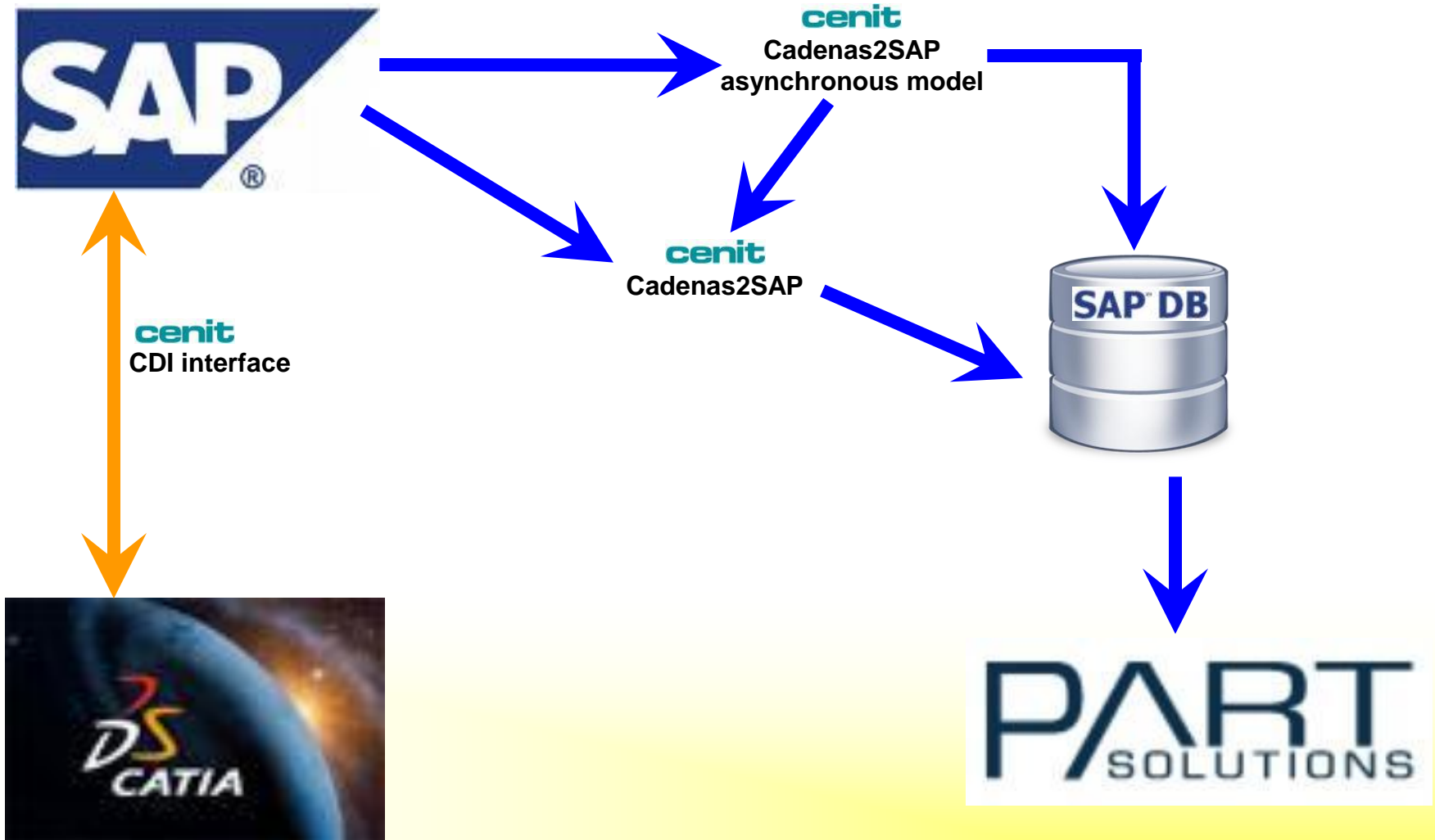

Implementation Classification

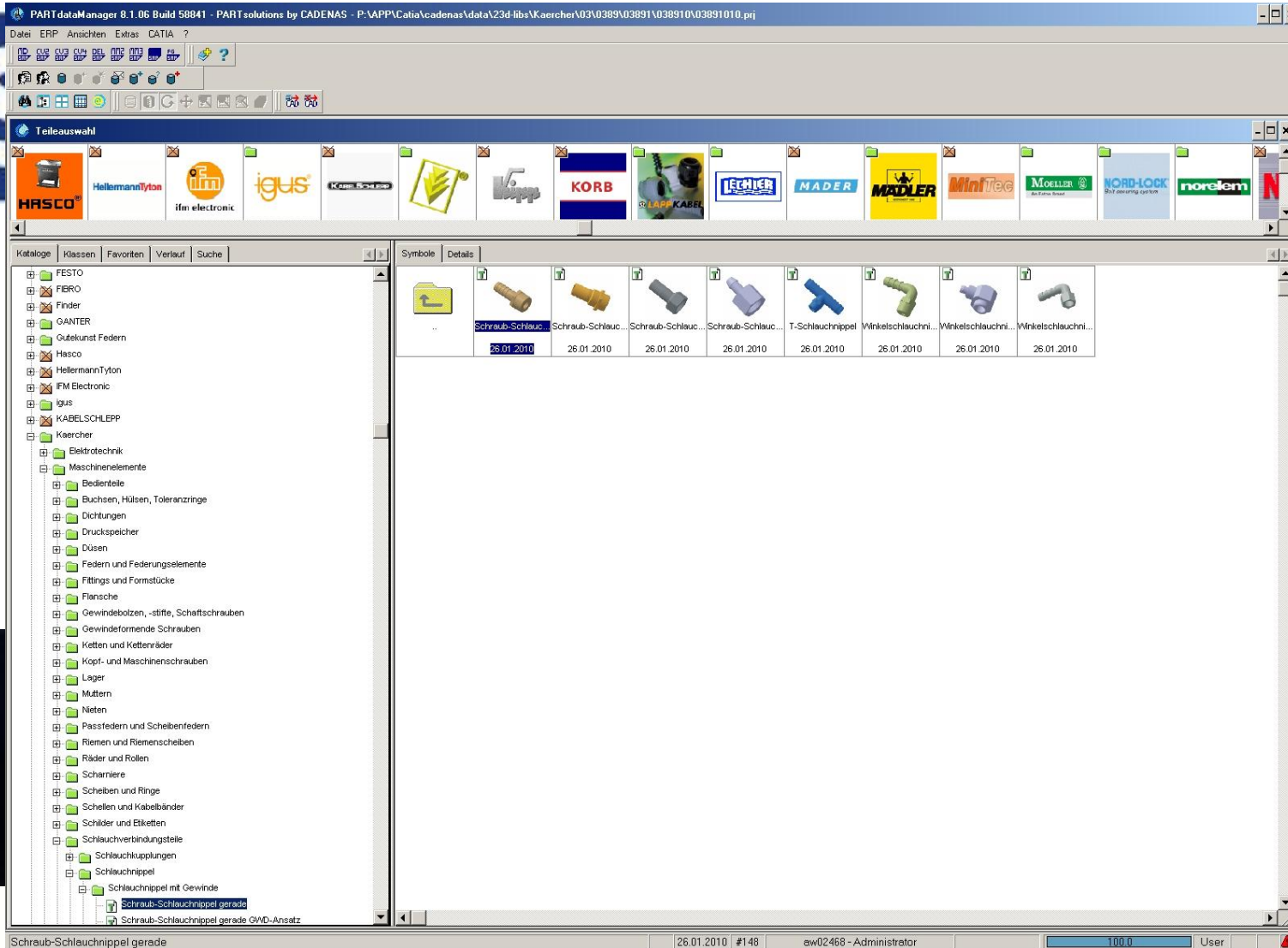

Implementation Classification

PARTdataManager 8.1.06 Build 58841 - PART solutions by CADENAS - P:\APP\Cata\cadenas\data\23d-libs\Kärcher\03\0389\03891\03891010.pri

6.388-348.0

	SAP_MAT SAP Mat. Nr.	Mat.-Kürztext	MAKTXD	MSTAE Mat. Status	DIS Dokumenteninfosatz	DIS_STATUS DIS Status	A Schlauchnenn...	B1 Gewindekenn...	B21 Gewindenenn...	B224 Gewindedurch...	B222 Gewindedurch...	B3 Gewindesteig...	Länge -S
74	5.443-299.0		Schlauchnippel	F			13	R		1/4"			30.
75	6.388-413.0		Schlauchnippel	F	5072827_SPA_000_01	FR	14	G		1/2"			
76	6.391-374.0		Schlauchnippel	F	5200851_SPA_000_00	FR	14	R		1/2"			
77	6.646-968.0		Gewindestuelle 1/2"	F			14	R		1/2"			
78	6.470-171.0		Schlauchnippel 1.4571	F	5128037_SPA_000_01	IA	16	G		1/2"			
79	6.388-348.0		Schlauchnippel 1/2"	F	5092630_SPA_000_00	FR	16	G		1/2"			
80	6.389-221.0		Schlauchnippel 1/2"	F	5092321_SPA_000_02	IA	16	G		1/2"			32.
81	6.395-201.0		Schlauchnippel G3/8"	F	5084787_C3D_000_00	FR	16	G		3/8"			
82	5.443-294.0		Schlauchnippel	F			16	M	18.0			1.50	30.
83	6.996-809.0		Schlauchnippel DN15	F			16	R		1/2"			
84	6.389-692.0		Schlauchnippel 1/2"	F	5121466_SPA_000_00	FR	16	R		1/2"			32.
85	6.390-845.0		Schlauchnippel 3/4x16, 1.4571	F			16	R		3/4"			
86	6.388-598.0		Schlauchnippel R3/4"	F	5127846_SPA_000_00	FR	16	R		3/4"			
87	6.388-636.0		Schlauchnippel R3/8"	F			16	R		3/8"			
88	6.388-584.0		Schlauchnippel	F	5097735_SPA_000_00	FR	19	G		1/2"			
89	6.386-611.0		Schlauchnippel 3/4" / 3/4"	F	5067771_C3D_000_00	FR	19	G		3/4"			28.
90	6.389-658.0		Schlauchnippel	F			19	NPT		1/2"			30.
91	6.395-240.0		Schlauchnippel Edelstahl 1" x 19 mm	F			19	R		1"	1.0000		
92	5.443-301.0		Schlauchnippel	F	5099588_SPA_000_00	FR	19	R		1/2"			30.
93	6.388-612.0		Schlauchnippel R3/4"	F	5070568_SPA_000_02	FR	19	R		3/4"			26.
94	6.388-696.0		Schlauchnippel 1"	F	5205919_SPA_000_00	PK	20	G		1"			

6.388-348.0

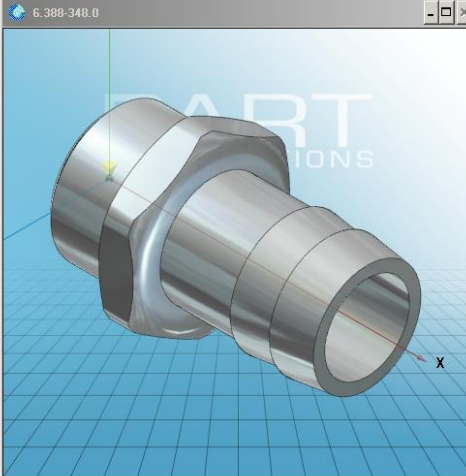

Verweise

Einstellungen

Technische Angaben

03891010

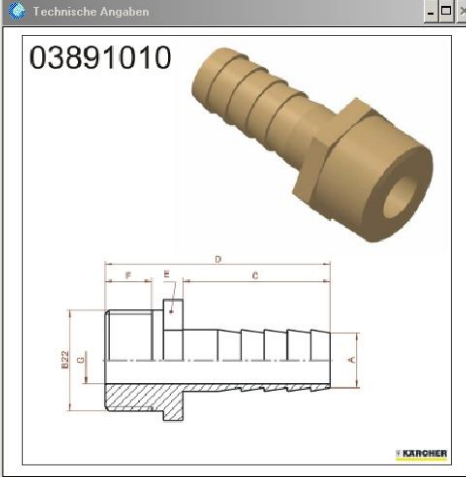

Schraub-Schlauchnippel gerade

26.01.2010 #148 aw02468 - Administrator 100.0 User

Implementation Classification

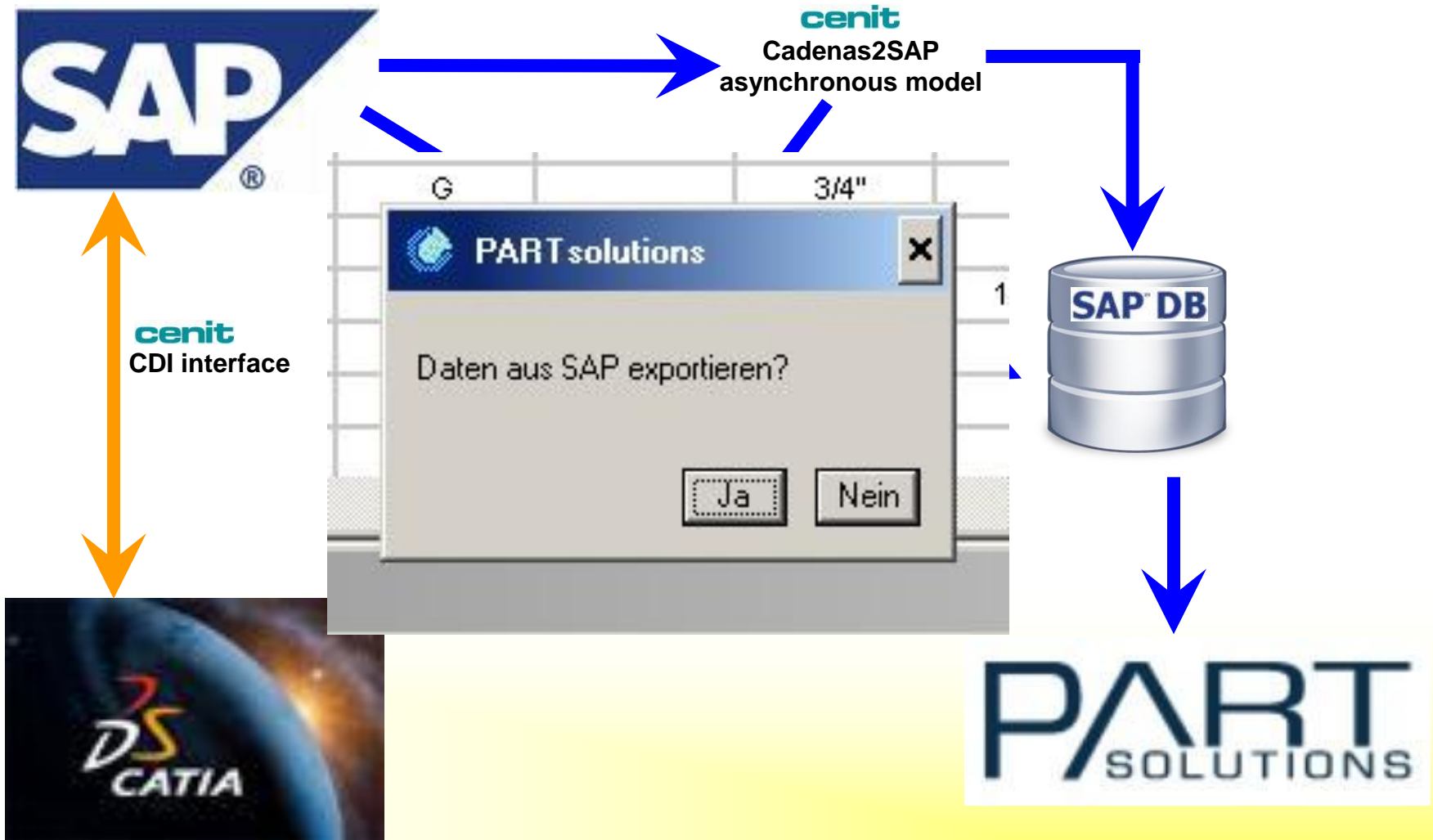

Implementation Classification

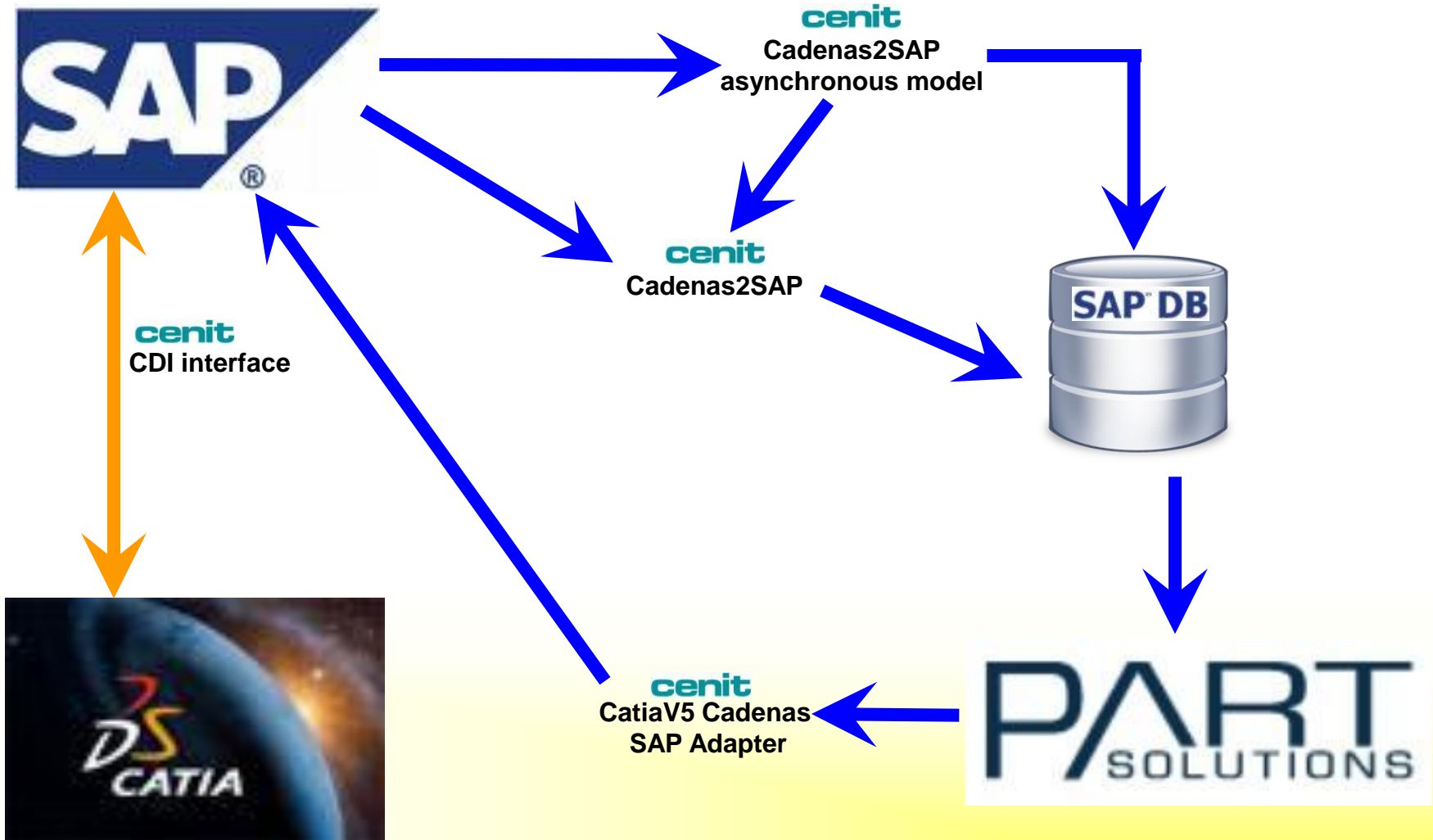

Future Prospects

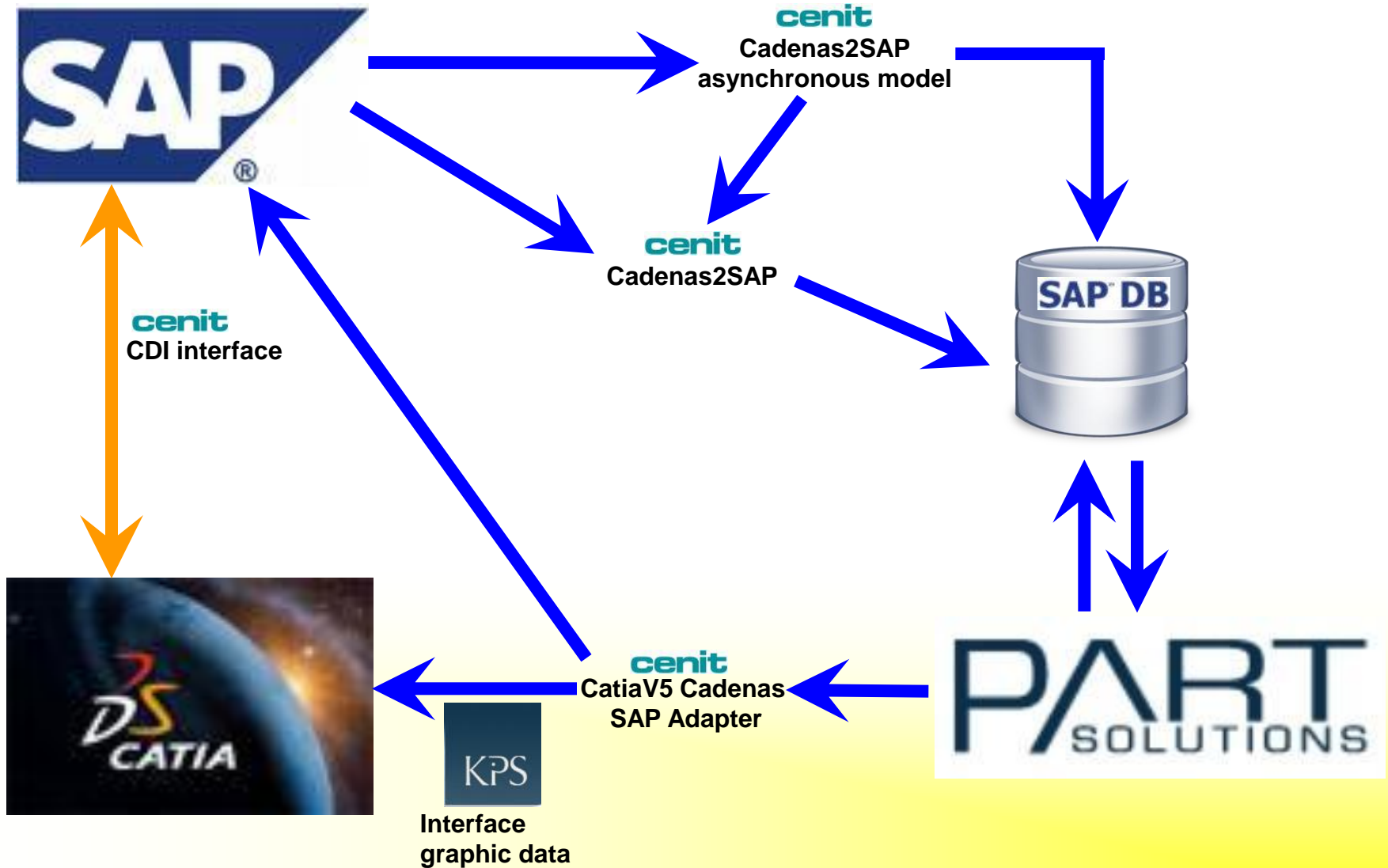

Future Prospects

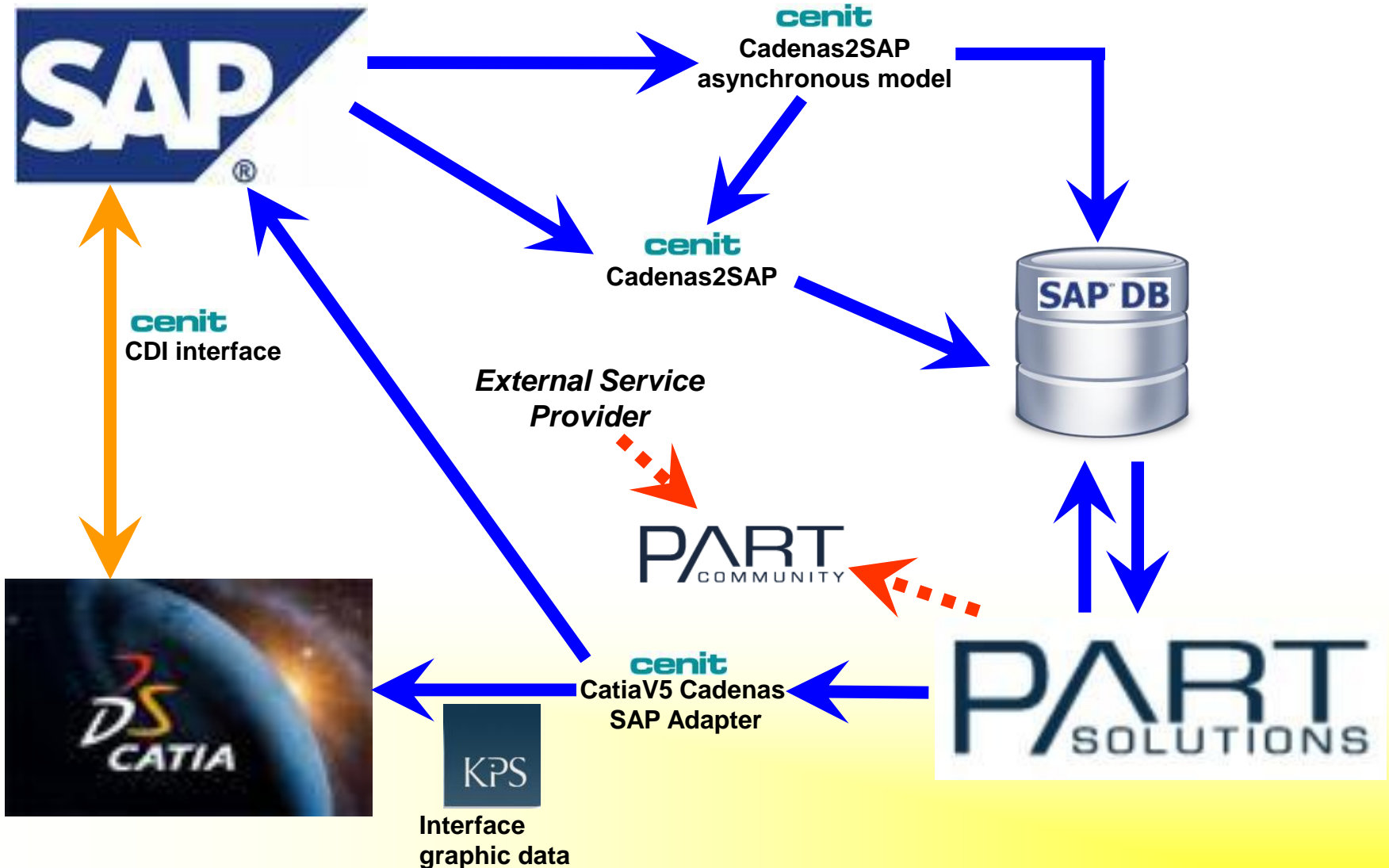



Thank you for your attention!
Questions?